

A NEW METHOD FOR THE GENERATION AND USE OF FOCUSED ULTRASOUND IN EXPERIMENTAL BIOLOGY

By JOHN G. LYNN, RAYMUND L. ZWEMER, ARTHUR J. CHICK, AND
AUGUST E. MILLER

(From the Departments of Neurology and of Anatomy, College of Physicians and Surgeons,
Columbia University, New York, and the Piezo-Electric Research Laboratories, North
Bergen, New Jersey)

(Received for publication, July 6, 1942)

INTRODUCTION

Ultrasonic, or supersonic waves as they are sometimes called, are mechanical vibrations in solid, liquid, or gaseous mediums lying above the range of human hearing. They have been produced mechanically and electrically, utilizing magnetostriction and piezo-electric effects. The latter method is the only one which is adapted to the generation of ultrasound at frequencies above 500 kc., which is the range most often used in biological work. It consists of passing a high frequency electric current through a quartz plate, so that the latter expands and contracts in resonance with the alternations of the current passing through it, and emits ultrasound waves of a corresponding frequency.

The biological effects of supersound were first thoroughly studied by Wood and Loomis (1) in 1926-27 at Tuxedo Park, New Jersey. They observed its stimulating and lethal effects on unicellular organisms, tissues, small fish, and animals. Since then, a host of subsequent investigators have expanded our knowledge regarding the thermal, chemical, and photochemical effects of ultrasound. Its dispersive power, its ability to produce stable emulsions between immiscible fluids such as mercury and water, and its stimulating and destructive effects on virus, bacteria, potato shoots, and animal tissues *in vitro* and *in vivo* have also been studied.

To date, all biological and neurological applications of supersound have utilized plane waves, proceeding in parallel paths from the flat surface of the quartz crystal generator, and no attempt has been made to increase their local intensity by bringing them to a focus. However, some years ago, this possibility was suggested by the late Dr. James Chiles of the University of Virginia.

Purposes of the Present Investigation

We have attempted to apply biologically the physical discovery of Grutzmacher (2) (1935) that very short ultrasonic waves can be focused by giving a concave curvature to the surface of the vibrating quartz plate, constituting the source of radiation. Thus, he was able to concentrate approximately 150 times as much ultrasonic energy at the focal spot as could be found at a similar spot close to the vibrating plate.

The chief aim of the present study has been to project such a focused beam of supersonic into fresh tissue blocks and into the tissues and organs of living animals, so as to produce a maximum of change deep at the spot of focus with a minimum of change in the intervening tissues traversed by the beam before it reaches the focus. While much more work has still to be done towards determining the optimum frequency, exposure time, intensity, etc. necessary to produce such focal effects in deep lying tissue, yet sufficient progress has been made in developing an efficient focusing ultrasound generator and in applying it to biological and neurological material to justify this early report.

The Radio-Frequency Power Generator

The oscillating electrical potential across the opposite faces of the x-cut concave quartz crystal, ground to a natural frequency of 835 kc., is supplied by what amounts, in principle, to a small $\frac{1}{2}$ kw. radio transmitter, such as is used for code signalling. Both a rear view photograph, Fig. 3, and a schematic diagram, Fig. 1, are given.

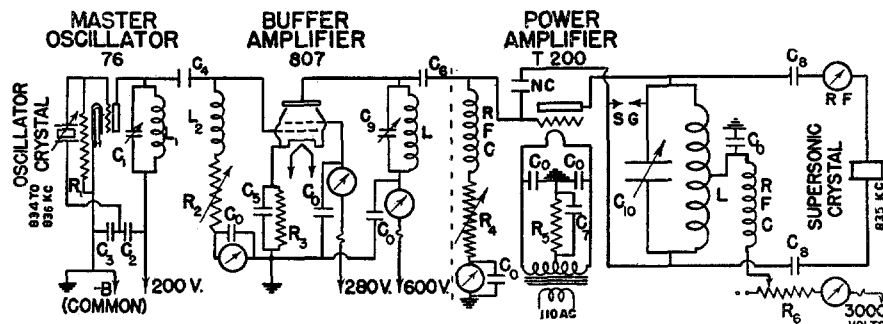

FIG. 1. Wiring diagram of the radio frequency power source for the ultrasonic generator. Full details of the circuit are given in the text.

The apparatus is so constructed (Fig. 3) that the bottom shelf holds the power source, the middle shelf houses the master control crystal oscillator and the first amplifier buffer stage. The output of the latter is conducted by means of a special cable through the inner shelf shielding to the top unit—the power amplifier. The entire set-up is shielded and carefully grounded to prevent radio interference, for safety against high voltage, and to prevent inter-stage feed-back. Special features of each of the above stages will be taken up in turn.

The power supply is a filament heating power and plate voltage source. The design used is that of a full wave mercury vapor rectifier circuit (type 866) with choke input filter. Although not entirely necessary, a filter adds to the stability of output voltage and helps to solve the radio interference problem, of which this set-up has given no signs. The rectifier operates on regular 110 volt, 60 cycle house current, and has a maximum output of 6000 volts d.c.

The master crystal control oscillator (Fig. 1) utilizes an ordinary receiver type triode (type 56 or 76, depending on the filament heater voltage available). This is loosely coupled with the grid of the tube in the buffer stage.

The buffer stage utilizes the R.C.A. 807, a newly developed beam-power tube with high power sensitivity. This provides the grid driving power necessary for Class C operation of the power amplifier T-200 tube on the top shelf (Figs. 1 and 3).

The radio-frequency voltage to the ultrasonic crystal is controlled by varying the d.c. voltage to the plate of the power amplifier tube. This is accomplished by a voltage dropping variable resistor (Fig. 1, R_6). To prevent initial transient voltages, while turning on the circuit, from becoming excessive, the best procedure was to put all this resistance in the circuit before turning on the T-200 plate voltage. Then the resistance may be decreased until any predetermined radio-frequency ammeter reading (R.F.) is reached. A spark gap (S.G.) is included across the tuned output circuit to take transient voltages that might otherwise injure the crystal. For long tube life, resistor R_6 must be at maximum when the crystal or other load is not coupled to the power amplifier; otherwise the available power for this efficiently adjusted stage may have to be dissipated entirely in the anode of the tube.

Resistor R_5 acts as a "safety-valve" to limit the current to the plate, which, if overloaded too often, may result in the tube current becoming erratic due to gases given off from overheated parts. As the power amplifier draws more and more current, the voltage drop across R_5 automatically increases, to put a higher negative voltage on the grid of the T-200 tube. Such protection is valuable when tuning adjustments are made, or in case the master oscillator crystal should fail to oscillate, or in the event that anything should stop the driving power to the grid of the power tube. Resistors R_2 and R_4 are adjusted with peak load for the maximum radio-frequency current to the supersonic crystal.

In the R.F. output circuit, fixed condensers, C_8 , bypass the alternating current but isolate the supersonic crystal and its container from the high-voltage direct current on the plate of the power amplifier tube. Not only do these condensers provide safety for the operator, but they also help to neutralize the inductance of the long leads to the supersonic crystal.

In the construction of a radio-frequency generator of this kind, compactness of parts and efficiency usually go hand in hand. All radio-frequency connections should be made with short heavy wires. Care was taken to have all ground for the buffer stage connect to one common centrally located point on the chassis, which was, in turn, grounded to a water pipe. Tuned circuits were adjusted for minimum plate current, or just a little past this point for stability. An outline of the proper procedure for neutralizing and tuning a master oscillator power amplifier such as this one is given in the Radio amateur's handbook obtainable in any library.

The chief feature of the foregoing design is the use of a quartz crystal as a master oscillator instead of an inductance and a capacity in the first grid circuit. The final ultrasound generating crystal is ground to match this oscillator crystal, so that the entire unit may be tuned to resonance and neutralized once and for all. "Fishing" for the supersonic crystal frequency is unnecessary. A vernier adjustment, built into the master oscillator crystal holder, allows a very slight frequency shift (834-836 kc.) so

that it is possible to set it at exact resonance with the driven ultrasound crystal (835 kc.). This gives a maximum power transfer, which, together with the accurate and stable means of tuning, accounts in part for the high supersonic output obtained with the relatively low radio-frequency power available.

The Focusing Ultrasound Generator

A special crystal mounting, holder, and container had to be designed to meet the unusual requirements incidental to the most efficient operation of a curved crystal from which focused ultrasound could be applied in any selected direction, to a predetermined depth, in the tissues of living animals (Fig. 4). Only innovations and improvements of design will be described here. Standard practice is followed in many details which are thoroughly described in *Ultrasonics* by Bergmann (3).

The ideal crystal mounting must provide a firm support yet allow the quartz to vibrate freely with a minimum of restraint at the edges or dampening of the surfaces. Both of these factors reduce ultrasonic output, and, in addition, restraint of the edges produces distortion with a tendency for the crystal to crack. Bechmann (4) partially solved the latter problem and reduced dampening by freely mounting the vibrating quartz on three pointed ivory pins which contacted the crystal at the nodal line along its grooved edge. Oyama (5), Grutzmacher (6), and Dognon, Dognon, and Biancani (7) utilized an air chamber behind the crystal. This not only reduced dampening effects, but also acted as a reflector of high-frequency ultrasound, so as to more than double the sonic output from the other side. Technical difficulties have hitherto precluded the simultaneous adoption of the advantages of both mountings, but in the present design, their difficulties have been overcome and both the nodal line suspension of the quartz and the reflecting airchamber are successfully combined in the same mounting (Fig. 2).

Oil-impervious synthetic rubber and fairprene rubber cement have been utilized in mounting the focusing crystal along the nodal line of its beveled edge. This served the dual function of giving a firm but elastic mounting of a high dielectric character and also of providing an efficient gasket which sealed off the air chamber behind the crystal. In order, however, to allow for expansion of heated air in this chamber, a neoprene expansion bag was attached to its base (Fig. 2).

The crystal and its mounting are surrounded by transformer oil and held by three neoprene spreaders in the center of a thin-walled bakelite cup or holder with perforations in the bottom which allow for the free circulation of insulating oil into the space between the side walls of the mounting and those of the bakelite holder. This bakelite holder is also provided with a wide screw-on brass collar to which is soldered water-cooled copper coils. Thus, this broad-surfaced brass collar acts both as an oil cooler and as one electrode with spring extensions contacting the outer aluminized surface of the crystal. The holder with its contents is mounted on the end of a laminated bake-

lite plunger which can be moved back and forth so as to vary the depth of the ultrasonic focus in the material irradiated.

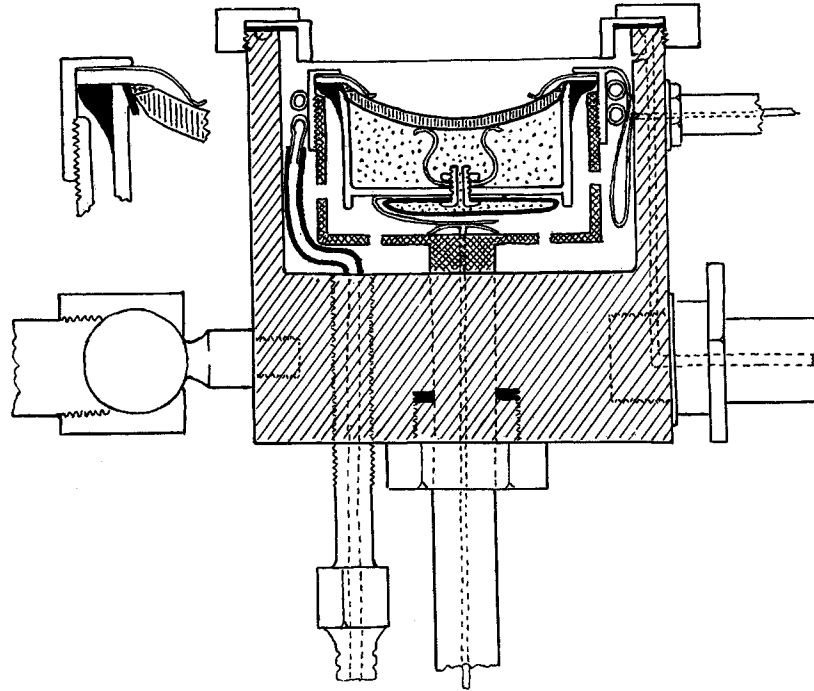

FIG. 2. Diagram of the ultrasonic generator. This is housed in a transparent bakelite container (diagonal lines) supported by a ball and socket joint (lower left). The container is sealed above by a cellophane diaphragm, against which biological specimens are placed; its interior is filled with transformer oil (clear), in which the curved quartz crystal vibrates. The latter is mounted by its beveled edge on a neoprene gasket (black) attached to the margins of a bakelite cup. The interior of this cup forms an air-filled chamber (stipple) behind the crystal. Electrical leads (top right and bottom center) connect with spring contacts on the two aluminized faces of the curved crystal. The nodal suspension of the crystal by its beveled edge is shown in detail (upper left). Only one of the two water conduits (bottom left) is shown connected *via* neoprene tubing to the copper cooling tube on the outside of the brass electrode collar. A device for sucking out air bubbles under cellophane diaphragm is shown at lower right. Neoprene gaskets, spreaders, and air expansion bag are indicated in solid black.

The entire generator is immersed in transformer oil contained in a heavy-walled transparent bakelite cylinder. The oil is electrical insulating but ultrasound transmitting. Together they are efficient insulators against both the R.F. current and stray ultrasonic waves. The oil transmits the focused beam of supersonic waves to a thin

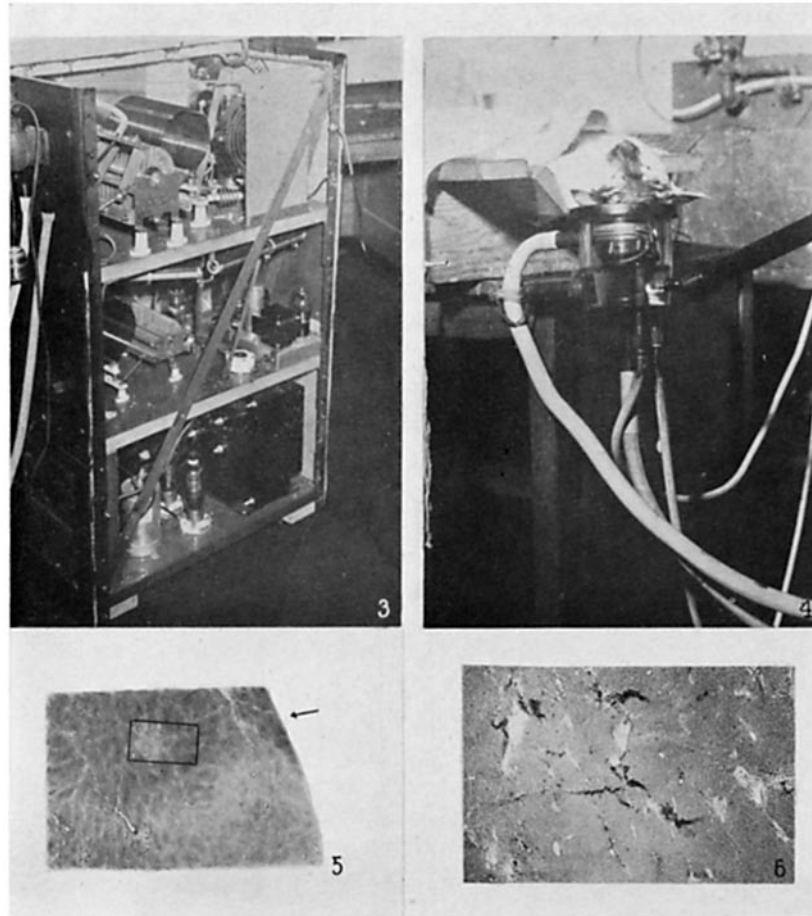

FIG. 3. Photograph of the back of the radio-frequency generator showing the three stages on separate shelves. See the diagram Fig. 1 and text for details.

FIG. 4. The ultrasonic generator is supported by a ball and socket joint at the end of a 3 foot arm, and can be applied to the animal in any position. The thick rubber tubing covers the electrical leads and the small tubes circulate cold water through the copper coil in the transformer oil surrounding the crystal. (See Fig. 2 for details.)

FIG. 5. Drawing of a thin section of liver showing region of application and focal point of ultrasound.

FIG. 6. Photomicrograph of a focal (left) and adjacent (right) region of the liver section in Fig. 5.

cellophane diaphragm which is in direct contact with the object or animal to be treated. Fig. 4 shows the entire set-up in actual operation with the head of an

anesthetized cat resting on the diaphragm 1.5 cm. above the supersonic crystal. The bakelite cylinder is mounted on a universal joint at the end of a 3 foot movable arm, which extends from the side of the radio-frequency generator. This flexible mounting permits ultrasonic application in a wide range of positions and elevations.

RESULTS

A. Propulsion of Oil.—Both the intensity and form of the beam of focused ultrasound was made visible by floating several millimeters of oil on the surface of the cellophane diaphragm. When the current was turned on, the supersonic radiation pressure drove the oil upward from the center of the diaphragm in the form of a conical column, from the top of which oil droplets were thrown upward and outward so that the entire phenomenon resembled an erupting volcanic cone. The height of the cone proper is a reliable but crude indicator of the ultrasonic output. The oil cone height increases with the plate voltage

TABLE I
Strength of Electromotive Force and Amount of Ultrasonic Output as Measured by Height of Oil Cone—4 Minute Tests

Test No.....	1	2	3	4	5	6
T-200 plate, <i>volts</i>	300	600	1600	1725	2025	2400
T-200 plate, <i>amp.</i>	0.030	0.060	0.115	0.125	0.170	0.220
R.F. output, <i>amp.</i>	0.100	0.200	0.520	0.700	0.800	0.900
Height of oil cone, <i>cm.</i>	0.4	1.5	6.0	10.0	11.5	12.5

and the R. F. output. However, the height reached by the droplets thrown from the top of the cone is usually about twice that of the cone itself.

With the cooling system in constant operation, 4 minute runs were made at the power settings listed in Table I. At each setting, a constant ultrasonic output was obtained throughout the test period, as indicated by the constant maintenance of the height of the oil cone with constant meter readings. The specifications for the ultrasonic quartz plate used in the following tests, as well as in all subsequent experiments reported herein, are: round, diameter 5.08 cm., frequency 835 kc., curved to focus at a point 5.5. cm. from concave crystal surface, and 4 cm. above the center of the flat cellophane diaphragm.

It should be noted from Table I that with a plate current of 220 milliamperes and a potential of 2400 volts, there is a peak output of 900 milliamperes of R.F. current, which produces a sufficient ultrasonic output to raise a solid oil cone 12.5 cm. high from the diaphragm with spray erupting to twice that distance. This measure of ultrasonic output for the one-half kw. of power with 2400 volts available can be compared, for instance, with a maximum 10 cm. oil column attained from a flat quartz plate of equal diameter by Wood and

Loomis (1), who utilized 2 kw. of power with 50,000 volts on the plate of the power tube.

The chief factors contributing to the unusually high efficiency and ultrasonic output of this apparatus (with one-fourth the power and one-twentieth the voltage used by Wood and Loomis) are as follows: (1) The master crystal oscillator control creates a stable and maximum power transfer from the R.F. to the ultrasonic crystal. (2) The airchamber reflector behind the ultrasonic crystal at least doubles the output of ultrasound. (3) The suspension of the crystal by cementing the nodal line at its edge to a flexible neoprene rubber gasket provides maximum freedom from dampening and stress during vibration. (4) The focusing crystal drives the oil from the base towards the apex

TABLE II
Paraffin Melting Defects Produced by Focused Ultrasound

Paraffin block.....	1	2	3	4	5	6
T-200 plate, volts.....	0.290	600	1600	1730	1730	1730
T-200 plate, amp.....	0.030	0.060	0.115	0.130	0.130	0.130
R.F. output, amp.....	0.100	0.200	0.520	0.700	0.700	0.700
Total exposure time, sec.	30	30	30	30	15	10
Time from 0 to power indicated, sec.....	5	5	5	5	5	1
Diagram of longitudinal section of melting defect.....						

of the radiation cone, where it accumulates and is piled up so as to exceed the 5.5 cm. focal length of the crystal. (5) The oil cooling system prevents the crystal temperature from rising sufficiently to lower its frequency, disturb its resonance, and so reduce the ultrasonic output.

B. Paraffin Blocks.—Preservation and demonstration of the conical effects in solid form was obtained by resting cubes of paraffin (m.p. 58° C.) in the film of transformer oil on top of the diaphragm just over the focus. A film of mineral oil, olive oil, lanolin, or normal salt solution must be between the diaphragm and the surface of the object irradiated to insure the displacement of all air. Air, if present, reflects and disperses the sonic beam. In the tests and experiments reported here we used 4 or 5 mm. of transformer oil.





With the crystal 1.5 cm. below the diaphragm, it was found by actual experiment that the focus, as indicated by the melting defect in the paraffin, was always 1.9 cm. above the diaphragm. This means it was 3.4 cm. above the

crystal, in contrast to the 5.5 cm. focal distance for which the crystal curvature was ground. The shorter focal length in actual practice can only be due to refraction effects which occur as the beam passes from the inside oil, through the diaphragm, outside oil film, and into the paraffin block.

Table II illustrates six representatives of several dozen experiments carried out with paraffin blocks at different intensities and exposure times.

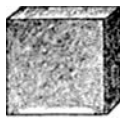
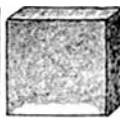
Maximum focal with minimum base effects were obtained only with high intensity and short-time ultrasonic exposures (blocks 5 and 6). The probable reasons for this phenomenon and its bearing on our basic problem will be taken up in the discussion.

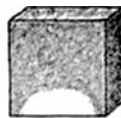
TABLE III
Beef Liver Changes Produced by Focused Ultrasound

Liver block experiment.....	1	2	3	4	5
T-200 plate, <i>vols</i>	600	1750	1750	2410	2410⇌ +
T-200 plate, <i>amp</i>	0.060	0.120	0.120	0.220	0.220⇌ +
R.F. output, <i>amp</i>	0.200	0.700	0.700	0.900	0.900⇌1.00 +
Total exposure time, <i>sec</i>	30	30	180	30	20
Time from 0 to power indicated, <i>sec</i>	10	10	10	10	Instantaneous
Diagram of longitudinal section of liver changes.....					

C. Beef Liver Experiments.—Blocks of animal tissue were next placed on the film of oil on the diaphragm and irradiated in a manner similar to the paraffin blocks. Liver from a freshly killed animal was found to give the most easily observed results, because the strongly irradiated portions turned grayish-brown, leaving the rest of the tissue a deep maroon color. Table III was compiled from a series of ten such experiments.

Focusing effects could only be obtained when full power was applied *instantaneously* as in liver block experiment No. 5 (Table III). See Figs. 5 and 6 for a microphotograph of a section through this liver block. A very small amount of cell destruction has occurred on the surface of the base. Lying above this, there is a region of unaffected liver cells, and finally a well defined focal point of severe destruction can be seen.

The significance of the foregoing findings on beef liver, and their bearing on the basic problem of achieving focal stimulation or destruction of cerebral tissue will be discussed in a later section.

D. Radiation of the Brain in Living Animals.—In view of the foregoing preliminary experiments with blocks of paraffin and liver tissue, it seemed probable that the present ultrasonic set-up with its high-frequency, limited R.F. power output, and small area of application to the scalp could not be expected to produce focal changes in the brain without simultaneous injury to the surface tissues, lying at the base of the cone of radiation. This proved to be the case, since all five animals (three cats and two dogs) showed more or less severe injury to the scalp in the area of application; while only those two animals which were exposed to radiations of maximum intensity showed any signs of local cerebral effects. In one dog, there was a transient injury to the upper portions of the precentral gyri, inferred from a weakness and incoordination of the hind extremities lasting about 16 hours. A cat, treated over the occipital visual area, showed blindness lasting for several hours which was followed by recovery.

DISCUSSION

An analysis of the results should give a better understanding of what occurs when a focused beam of ultrasound is applied to non-living and living material. For with a better comprehension of the processes involved, it should be possible to define more clearly the directions in which technical improvement in the generation and application of focused ultrasound must proceed if it is to be developed into a practical agent for the local modification of brain function.

The paraffin melting defects obtained and diagrammatically represented in Table II can be explained by simple thermodynamic principles which apply to the accumulation of heat (58°C.) to produce local melting in a uniform medium such as paraffin. The chief determinants of the amount of local heat accumulated in unit of material for unit time are: (1) rate of heat generation, and (2) rate of heat dissipation.

The rate of heat generation in any local region of the paraffin varies directly with the local intensity of ultrasonic radiation. The local intensity is dependent on the amplitude of crystal vibration which varies directly with the R.F. voltage applied to the quartz and with the concentrating effects of focusing. The latter increases from a minimum to a maximum per unit mass as one proceeds from the base to the focus of the radiation cone.

In contrast, the rate of local heat dissipation varies directly with the proximity of the heated region to cool non-radiated region of paraffin. Thus, at the focal spot, where the heat generation is greatest, its dissipation to immediately adjacent cool areas is also greatest; while a similar spot at the center of the base region, remote from any cool non-radiated paraffin has minimum dissipation.

It is this base-to-focus variation in the ratio of heat generation to heat dissipation which gives a base-to-focus gradient in heat accumulation, manifest in amounts of melting in these regions. The form of this base-to-focus gradient in heat accumulation, has been found in the paraffin block experiments to be reflected in the form of the melting defect. This form was found to vary with both the intensity and the duration of the supersonic output.

In paraffin block 1 (Table II) the intensity of the ultrasonic output was so low as to be insufficient to produce heat generation at the focus faster than it was conducted away by the cooler non-radiated adjacent regions. Hence, there are no focal signs of melting. In the base, however, despite the lower heat generation per equal unit of paraffin, the heat dissipation, especially near the center, is so slow that there is sufficient heat accumulation in 30 seconds to reach 58°C. and to melt out the basal defect shown.

With an increase in intensity of ultrasonic output, the rate of heat generation may exceed the rate of its conduction from the focal region, so that there is sufficient accumulation of heat in 30 seconds to produce melting at the focus as well as at the base (see paraffin block 2, Table II).

With further stepping-up of the intensity of irradiation, the rate of heat generation becomes still greater as compared to its rate of dissipation. Hence, the heat accumulation, as indicated by the melting defects at the focus and base, becomes proportionately larger and larger until they finally merge (paraffin blocks 3 and 4, Table II).

It is only when high ultrasonic power is applied for a short 15 or 10 second period that there appears a relatively greater heat accumulation at the focus with complete melting at this region, as compared to a centrally located incomplete melting at the base (blocks 5 and 6, Table II). This phenomenon is understandable when it is realized that the rate of heat generation is maximum the instant full power is applied, and this maximum is maintained throughout; while the achievement of a maximum heat dissipation by conduction must be a sequel to its generation and takes more time. Therefore, when the exposure time is sufficiently short, heat dissipation becomes less and less a factor determining the amount of heat accumulated in a local area. Thus, when, in experiments 5 and 6, the exposure times are for 15 and 10 seconds respectively at high power, the amount of heat generated becomes the major determiner of the amount of heat accumulated at the base and focus respectively. This is in contrast with experiment 4 at the same power for 30 seconds, where a large melting defect occurred at the base.

The results of the beef liver experiments can now be analyzed. Fresh tissue is not a uniform medium like paraffin. Instead it consists of a multitude of protoplasmic interfaces which act to reflect, refract, and so to produce absorption of the ultrasonic radiations. Thus, the absorptive capacity of fresh beef

liver for supersonic should be much higher than that of paraffin.¹ This was found to be the case in the experiments in which the dosage was slowly increased to maximum intensities where only basal effects were produced (liver experiments 1 to 4, Table III). Apparently, the radiations were all absorbed before they reached the focus in sufficient intensity to produce any change in this region. However, when full power was *instantaneously* applied, a well defined focus was obtained (experiment 5, Table III and Fig. 5). Success under these conditions might be due to the transient but very high surge of power which always accompanies instantaneous switching-on of current. This was registered on the R.F. ammeter as an initial reading of over 1.00 ampere, with an immediate dropping-back of the pointer to a stable maximum output level of 0.9 amperes. Only when this initial peak surge of R.F. output occurred could sufficient ultrasonic intensity be obtained to produce a focal concentration strong enough to cause focal destruction in fresh liver tissue.

The work of Dognon, Dognon, and Biancani (7), Harvey (8-10), and others shows that unicellular organisms are more vulnerable than multicellular organisms to ultrasonic waves. Furthermore, with an increase in the size of the animal, its resistance increases, especially if it happens to acquire the protection of a shell covering.

In the case of the experiments on living animals, there was ample evidence to indicate that with the intensities available, immediate tissue injury with irreversible changes resulting in scalp ulcerations occurred only when applications of at least 5 minutes were used at medium or high power. Furthermore, the region of chief injury was in the superficial soft tissues at the base of the radiation cone where both heat conduction and blood circulation are less than at the focus in the brain. The experiments of Gohr and Wedekind (11) emphasize the important rôle that circulating blood and tissue fluids play in protecting against the injurious effects of ultrasound applied *in vivo*, despite the high absorptive capacity of the tissues treated. They exposed the abdominal skin of an anesthetized rabbit to supersonic waves. There occurred a slight skin erythema with hyperemia, while inside there were peritoneal hemorrhages with dilation of the intestine. However, when the same treatment was applied to an animal killed immediately before exposure, they observed rupture of skin vessels, changes in blood pigment, and innumerable perforations of the gut with passage of fecal matter into the peritoneal cavity. The dissipation of heat should be especially effective in the brain, because of the richness of its vascular supply.

A factor contributing to skin injury may have been the use of irritating trans-

¹Dognon, Dognon and Biancani (7) found that liver tissue in a standard aluminum capsule had the same absorption as paraffin for ultrasound as indicated by temperature measurements. However, the condition of the liver in regard to freshness and cell structure are not given.

former oil rather than bland olive oil or normal salt solution as a skin contact medium. Frenzel (12), Pohlman, Richter, and Parow (13) have shown that ultrasound increases skin permeability, which, in conjunction with the radiation pressure, causes rapid absorption of drugs and other substances.

In the two animals which received exposures of maximum intensities over periods of 12 to 24 minutes respectively, behavior changes occurred which lasted for some hours, and which indicated damage in the local brain areas involved. However, this change was temporary. The refracting and reflecting effects of the layers of head tissue of different density such as skin, subcutaneous tissue, bone, membranes, and brain substance, must inevitably produce some diffusion of the focusing effects. When one of the animals was brought to autopsy just after recovery from the blindness produced, actual edema and hyperemia of the brain and pia were observed locally in the cortical visual area affected, while the remainder of the brain appeared normal.

Future Developments and Applications of Focused Ultrasound

As a result of this study, improvements can be made in the present focused ultrasonic generator which should enable one to produce local changes in tissues in general or in the brain in particular with a minimum of complicating injuries to superficial tissues. This basic problem has already been faced and partially solved in the case of x-ray therapy. Here, the chief means of solving the difficulty have been by perforated lead screens, multiple beams, circular motion of the source of radiation, or by actual rotation of the object radiated so that the x-ray beam sweeps over a wide area of skin surface. Because of the very short wave lengths involved, focusing has not been found practical with x-rays. However, with the use of ultrasound, focusing is very practical in the frequencies lying above 250,000 per second, where the wave length in water is 6 mm. and less. The following lines of development would seem to be indicated in order to further reduce skin effects and increase focal changes.

1. Use of a non-irritating skin contact medium such as normal saline, olive oil, or lanolin on the diaphragm of the supersonic generator.
2. Use of one-half to one-third of the present frequency. Since absorption increases as the square of the frequency in water (Langevin) and there is suggestive evidence pointing to almost equivalent absorption increase with frequency in tissues (Pohlman and Richter), this frequency reduction would seem advisable. With less absorption in the skin and superficial tissues, there would be a larger proportion of the radiation penetrating to the focus at any given output intensity.
3. Grinding of the crystal to a curve with as short a focal distance as is consistent with experimental needs. This obviously increases the intensity of the focal effect without increasing the skin effect.

4. Application of the treatment at maximum output intensity for the minimum period of time necessary to produce focal changes. This follows from the results of the paraffin and liver block experiments, where it was found to be the most efficient means of applying ultrasound in order to obtain maximum deep focal with minimum superficial changes.

5. Use of a mosaic of 4 to 6 two-inch curved crystals, all focusing on a common point. This would not only increase the focal effect, but would spread the base effect over four to six times the skin area of the present set-up.

6. Increase of the power of the R.F. generator to about 3 kw. This should provide sufficient voltage to drive efficiently the mosaic of 4 to 6 two-inch crystals, each twice as thick (one-half the frequency) as the single quartz plate now in use.

CONCLUSIONS

1. An efficient generator of focused ultrasound has been designed, built, and successfully operated.

2. The generator has been used to produce focal heating in the centers of paraffin blocks, and in a similar manner, focal areas of destruction were obtained deep in fresh liver tissue with minimal effects at the surface and no effects on the intervening tissue.

3. In animals, focused ultrasound of high intensity produced local cerebral changes as inferred from behavior disabilities and as demonstrated at autopsy. This local brain effect was achieved through intervening scalp, skull, and meninges. The resulting behavior disabilities disappeared in from 2 to 16 hours.

4. To date, it has not been possible to produce such brain changes without incidental injury to the skin and subcutaneous tissue lying at the base of the cone of radiation.

5. Improvements in generation and application of the focused supersonic beam are suggested whereby it should be possible to increase still further the focal effects in the brain, with a corresponding decrease or elimination of complicating surface injury.

BIBLIOGRAPHY

1. Wood, R. W., and Loomis, A., The physical and biological effects of high frequency sound-waves of great intensity, *Phil. Mag.*, 1927, **4**, 417.
2. Grutzmacher, L. Piezoelektrischer Kristall mit Ultraschallkonvergenz, *Z. Phys.*, 1935, **96**, 342.
3. Bergmann, L.; Ultrasonics and their scientific and technical applications, Inc., London, Chapman & Hall, Limited, 1938, translated by Hatfield, H. S., from *Ultraschall*, VDI-Verlag, Berlin.
4. Bechmann, R.; Entwicklung der Quartzsteuerung der Telefunken-Gross-sender, *Telefunkenztg.*, 1934, **14**, No. 63, 17.

5. Oyama, H., Generation and application of intense supersonic acoustic waves, *Rep. Radio Research*, Japan, 1934, **4**, 41.
6. Grutzmacher, L., Ultraakustischer Richstrahler, *Z. techn. Physik*, 1936, **17**, 166.
7. Dognon, A., Dognan, E., and Biancani, H., *Ultra-sons et biologie*, Paris, Gauthier-Villars, 1937.
8. Harvey, E. N., Harvey, E. B., and Loomis, A., Further observations on effect of high frequency sound waves on living matter, *Biol. Bull.*, 1928, **55**, 459.
9. Harvey, E. N., The effect of high frequency sound waves on cells and tissues, *Am. J. Physiol.*, 1929, **90**, 379.
10. Harvey, E. N., Biological aspects of ultrasonic waves: A general survey, *Biol. Bull.*, 1930, **59**, 306.
11. Gohr, H., and Wedekind, T., Ultrasound in medicine, *Klin. Woch.* 1940, **19**, 25.
12. Frenzel, H., Hinsberg, K., and Schultes, H., Influence of ultrasound on diffusion, *Z. ges. exp. Med.*, 1935, **96**, 811.
13. Pohlman, R., Richter, R., and Parow, E., Conduction and absorption of ultrasound waves in human tissue and its therapeutic action in sciatic and plexus neuralgia, *Deutsch. med. Woch.* 1939, **65**, 251.