

ANESTHESIA PRODUCED BY DISTILLED WATER

BY W. J. V. OSTERHOUT AND S. E. HILL

(From the Laboratories of The Rockefeller Institute for Medical Research)

(Accepted for publication, June 21, 1933)

Experiments on *Nitella*¹ show that the cells lose their irritability when transferred from pond water or from a nutrient solution to distilled water. The process appears to be perfectly reversible as the normal irritability returns when the cells are replaced in the nutrient solution. Hence anesthesia appears to be produced by removing something from the cell.

The recording apparatus is essentially an electrostatic short-period voltmeter,² consisting of a Cambridge Type *A* string galvanometer with thermionic amplifier. The circuit arrangement is shown in Fig. 1. A selected 201 *A* vacuum tube with a grid to cathode D.C. resistance of over 100 megohms at free-grid potential is employed. This is used at free-grid potential without a grid leak, under which conditions the error in measurement of potential of a *Nitella* cell is less than 1 per cent. By the use of a series calibration (P_1) the error is reduced to a negligible value.

In operation, the plate-circuit resistance is adjusted until equal to the internal resistance (plate-cathode) of the tube at free grid.

The grid-biasing potentiometer (P_2) is then adjusted to free-grid potential. The *Nitella* cell or a calibration potential may now be thrown into the grid circuit, and the sensitivity of the instrument brought to the required value by use of the galvanometer shunt R_1 or by changing the tension of the string.

By operating at free-grid potential the grid current is kept at a minimum value and the galvanometer is protected if the circuit is accidentally opened. The use of plate-circuit resistance equal to the internal resistance of the tube gives maximum power amplification. Ample power is secured to operate the string galvanometer while drawing minimum current from the cell under examination.

¹ This is *Nitella flexilis* Ag., the species used in all previous work from this laboratory.

² Osterhout, W. J. V., and Harris, E. S., *J. Gen. Physiol.*, 1927-28, **11**, 391. Osterhout, W. J. V., and Hill, S. E., *J. Gen. Physiol.*, 1929-30, **13**, 547; 1930-31, **14**, 385, 473. Blinks, L. R., *J. Gen. Physiol.*, 1929-30, **13**, 361.

Reference to Fig. 2 will show the reason for employment of the amplifier. The voltage existing in the *Nitella* cell is distributed across R_1 and R_2 in direct proportion to their resistance. Four times the voltage applied to the grid circuit (R_2) of the 201 A tube is generated in the plate-circuit (R_3) which has only about 1/40

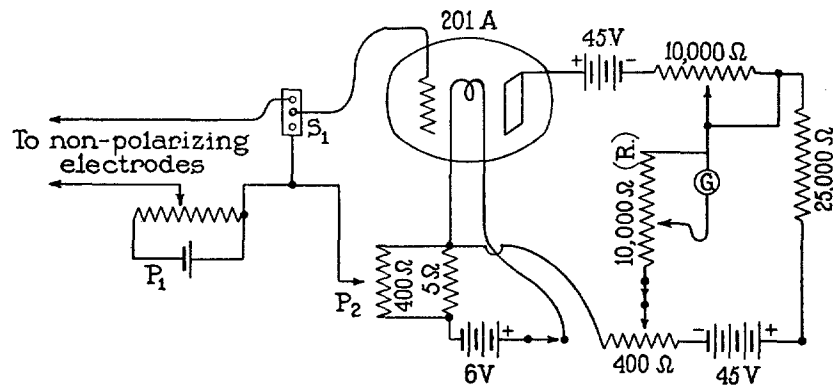

FIG. 1. Thermionic amplifier for galvanometer

G = Cambridge Type A string galvanometer

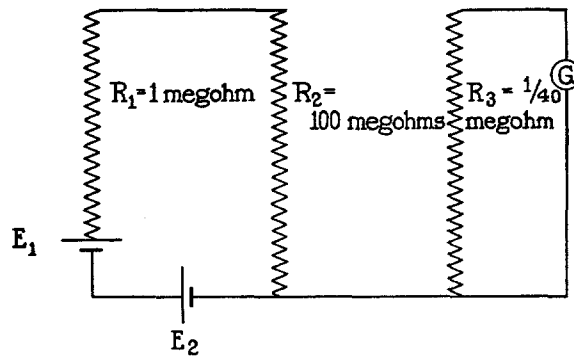

FIG. 2. Schematic diagram of vacuum tube amplifier employing 201 A radiotron.
 $E_1 R_1$ = voltage and resistance of *Nitella* cell.

E_2 = calibrating E.M.F. from source of negligible resistance (50 ohms per volt).

R_2 = grid to cathode resistance of 201 A radiotron.

R_3 = plate to cathode resistance of 201 A radiotron.

the resistance of the *Nitella* cell. The sensitivity of the galvanometer is about 160 times as great as it would be without the amplifier, while the current drawn from the *Nitella* cell is less than 1/100,000 of that which would be drawn by the galvanometer if connected direct to the *Nitella* cell.

The temperature in all experiments was 21–23°C. The experiments with distilled water were carried out in the following ways:

1. *Mass Cultures*

Cells were placed in a covered pan of enamelled ware containing a mixture of electrolytes which will be called Solution *A*. These gave action currents for 2 weeks³ during which period they were tested frequently. Solution *A* was then replaced by distilled water and left until their irritability was lost. When these cells were replaced in Solution *A* most of them regained their former irritability in 2 days: in some of these which were kept in distilled water for 8 days anaesthesia doubtless lasted a week since irritability probably disappeared in a day.

“Loss of irritability” as used in this paper means loss of ability to respond to a definite stimulus which was approximately the highest that could be applied without danger of injury (see p. 93). This was direct current applied for 3 seconds by means of two silver-silver chloride electrodes placed (about 1 cm. apart) at one end of the cell. A cell which does not respond in this length of time will not do so when the stimulus is prolonged indefinitely.

Cells were regarded as showing normal irritability when they responded to 50 to 160 mv. applied in this manner. In this experiment cells which did not respond to 400 mv. were regarded as having lost their irritability.

In a typical experiment, such as is described above, 25 cells were kept in Solution *A* for 2 weeks and all gave action currents (with 160 mv.) before being placed in distilled water. But of the 23 cells alive after 1 day in distilled water only 48 per cent responded and of the 21 alive after 3 days only 9 per cent responded. Replaced in Solution *A* 50 per cent responded after 1 day, 70 per cent after 2 days, 77 per cent after 3 days, 77 per cent after 4 days, and 87 per cent after 10 days. (During the experiment 68 per cent of the cells died: no account is taken of these in making up the percentages, which refer only to the living cells.) There was no loss of irritability during 16 days in the control cells kept in Solution *A*, except in dead cells (46 per cent of these cells died in 10 days and 53 per cent in 16 days).

The cells, placed on paraffin blocks, were surrounded by moist air except where

³ Cells often remained normal under these conditions for 10 weeks or more (each was a single cell from which neighboring cells had been cut away).

the contacts, consisting of moist cotton, were applied. The contacts were about 1 cm. apart.

The water was redistilled, using a pyrex glass flask and condenser, and rejecting the first third of the distillate (baffle plates were used to prevent mechanical contamination).

Solution *A* contains

CaCl ₂	0.001 M	Citrate	0.00001 M
NH ₄ Cl	0.00025 M	Tartrate	0.00002 M
MgCl ₂	0.00025 M	Phosphate	0.00003 M
NaHCO ₃	0.001 M		

To 1000 parts of this 1 part of sea water was added.

2. Individual Test-Tubes

In order to follow the behavior of individual cells 40 test-tubes were filled with Solution *A* and a cell was placed in each. Each of these cells gave action currents when stimulated electrically (160 mv.). Solution *A* was replaced by distilled water and the cells were again tested 24 hours later, at which time all responded.

Let us now consider the behavior of a typical cell (No. 3). After 2 days in distilled water it still gave action currents but after 3 days it no longer responded when 300 mv. were applied and it was therefore regarded as having lost its irritability. It was then transferred to Solution *A* and 24 hours later gave action currents: this was also true 2 days later when the experiment was discontinued.

We see that ability to respond to 300 mv. disappeared in about 3 days in distilled water and was regained in Solution *A* in about a day. Control cells, kept in Solution *A*, showed no loss of irritability (except in the case of those that died during the experiment).

Leaving out of account 23 cells which died⁴ during the experiment, let us consider the 17 which survived to the end (7 days). All were treated like Cell 3. Of these, 7 behaved like Cell 3 and the rest differed only in minor details (with the exception of 2 which continued to give action currents throughout the entire experiment). For example, 4 lost their irritability more quickly than Cell 3 at the start (*i.e.* after 1 day in distilled water) but all save 1 regained their irritability just as quickly as Cell 3 when transferred (on the 5th day of the experiment) from

⁴ The mortality seems to be due principally to the handling of the cells which have to be removed from the test-tubes for each test. Cells kept continuously in Solution *A* die much more quickly when handled than otherwise.

distilled water to Solution *A*. When this transfer was made all the cells except 4 had lost their irritability but all save⁵ 2 regained it in 24 hours in Solution *A*. All the cells responded when the next test was made 2 days later (8th day of the experiment).

In order to see whether the restored irritability could again be removed another experiment was made with a lot of 40 cells. A typical cell (No. 7) lost its irritability after 1 day in distilled water (no response to 500 mv.): tests on the 2 following days showed that this condition persisted. It was then transferred to Solution *A* where it regained its irritability in 1 day: a test on the following day showed that it was still responsive. It was then transferred to distilled water and a test 2 days later showed that it had again lost its irritability.

Hence it is possible to remove irritability, restore it, and take it away again.

Leaving out of consideration the 29 cells which died during the experiment, we may say that the 11 which survived to the end of the experiment (8 days) agreed with Cell 7 except in minor details. Thus at the start 6 were slower than Cell 7 in losing irritability (4 required 2 days and 2 required 3 days in distilled water). When the cells were afterward transferred to Solution *A* (after being 3 days in distilled water) 2 were slower than Cell 7 in regaining irritability: nevertheless they accomplished it in 2 days. When on the 6th day, after being 2 days in Solution *A*, the cells were transferred from Solution *A* to distilled water, 5 cells were slower than Cell 7 in losing their irritability but (with one exception) all these lost it in 3 days.

3. Treatment of Restricted Areas of the Cell

Under the circumstances it seemed worth while to ascertain whether distilled water applied to a restricted area of the cell would cause a local loss of irritability. This proved to be possible and it was found that the irritability could subsequently be restored.

A typical cell (No. 3) behaved as follows: With Solution *A* at *A*, *B*, *C*, and *F* (Fig. 3 with *D* and *E* omitted) stimulation (160 mv.) by means of the electrodes at *A* and *B* resulted in responses at *C* and *F*. The solution at *F* was then replaced by distilled water. After 24 hours *F* did not respond to 300 mv. but *C* gave a normal response. Tests on each of the 8 following days showed this situation to be unchanged.

⁵ These 2 regained their irritability later on.

The distilled water at *F* was then replaced by Solution *A* and after 24 hours *F* responded as well as *C*. In this case therefore local anesthesia lasted 8 days but there was no irreversible injury.

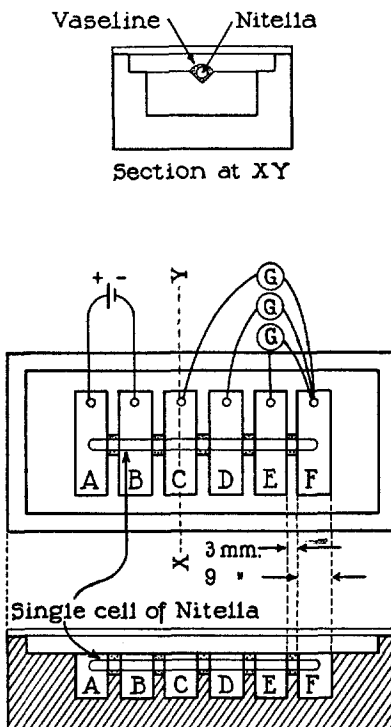

FIG. 3. A paraffin block containing 6 cups (*A*, *B*, *C*, *D*, *E*, and *F*) filled with solution is shown in cross-section above, in ground plan in the middle, and in longitudinal section below. Each partition has a notch filled with vaseline in which a *Nitella* cell is embedded as shown in the cross-section (above). In this way 6 different areas of the cell can be treated with different solutions. A cell may remain several days in the block without apparent injury.

Electrical connections are usually made as shown in the ground plan, *i.e.* from *C* to *F*, *D* to *F*, and *E* to *F* (here *G* signifies a string galvanometer with a vacuum tube amplifier; the apparatus is essentially electrostatic in principle).

In view of the fact that the protoplasm and sap of *Nitella* are in constant circulation it might be supposed that substances leached out of *D* by distilled water might be replaced from neighboring regions rapidly enough to preserve the irritability but this was not the case.

In this case 20 cells were employed. Leaving aside the 8 cells which died during the experiment we may say that the 12 which survived to the end of the experiment (11 days) behaved like Cell 3 except for minor differences. For example, at the start 3 were slower than Cell 3 in losing irritability at *F* but all lost it in 4 days. Furthermore 3 cells regained irritability at *F* somewhere between the 6th and 8th days although apparently in contact with distilled water (whether there was some contamination of the distilled water from the adjoining cup is not known). Also 5 cells took 2 days to regain irritability at *F* when (on the 8th day of the experiment) distilled water at *F* was replaced by Solution *A*.

The cells were placed in cups in paraffin blocks as shown in Fig. 3. These were prepared by running paraffin into steel⁶ molds so as to make 6 cups separated by 5 solid partition walls of paraffin about 3 mm. in thickness. In the center of each of these a vertical notch was cut to admit a *Nitella* cell. When the cell was placed in the block, as shown in Fig. 3, the cups *A*, *B*, *C*, *D*, *E*, and *F* were filled with solution. No liquid crept from one cup into the next under these circumstances because the space in the notch around the *Nitella* cell was filled with vaseline. The block was covered with a glass plate.

There was, of course, a capillary film of liquid surrounding the cell wall but this did not produce more short-circuiting than the ordinary experiments in air or in a moist chamber such as have been described in previous papers.

It is evident that the area at *F* which is treated with distilled water gives no response when a stimulus is applied by means of an outgoing electrical current at *B*, but we are unable to say what would happen if a stimulus were to be applied directly to the region in contact with distilled water.

In order to answer this question two methods were employed both of which showed that no normal response could be obtained.

1. Cells were used which had been kept in a paraffin block (Fig. 3) with distilled water at *A*, *B*, *C*, *D*, *E*, and *F* for 3 days. These places remained in contact with distilled water while the following test was made. In the circuit through *A* and *B* 500 mv. were applied in the usual way with an ingoing current at *A* and an outgoing current at *B*. As this produced no normal response it was gradually increased to 1200 mv. We led off in the usual way from *C* to *F* with electrodes in both cups, but the partition between *B* and *C* was removed so that these two cups were in contact with the same area of the cell. The record showed an increased negativity at *C* due to the applied E.M.F. which ceased when the current was broken. However, the negative potential at *B* fluctuated irregularly during the outward flow in a manner suggesting a breakdown of the protoplasm by the large current employed and a consequent change in effective resistance. There was no transmission to

⁶ Steel was preferred to copper or brass since it is not toxic.

D, *E*, or *F*: all points were in contact with distilled water during the experiment. With 300 mv. applied there was no such fluctuation in the negativity of *C* during the flow.

2. In the second method the circuit from *A* to *B* formed one arm of an equal-arm Wheatstone bridge as described by Blinks.⁷ The arrangement is shown in Fig. 4. We could then lead off to the galvanometer as shown in the figure and apply an electrical stimulus without having it affect the photographic record directly. In the record we see only the changes in P.D. which take place in the protoplasm. We found no normal responses at *B*: some irregular disturbances occurred at higher voltages but in no case were these followed by action currents at *C*, *D*, or *F*.

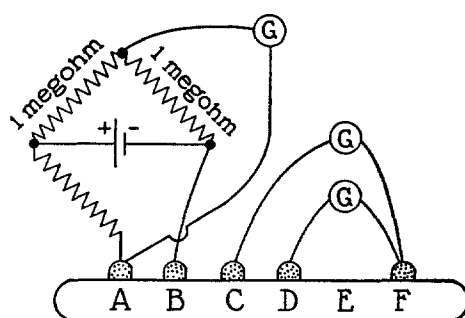

FIG. 4. Showing arrangement when the circuit through *A* and *B* constitutes one arm of an equal-arm Wheatstone bridge. In this case the stimulating E.M.F. does not affect the photographic record directly. Here *G* signifies a string galvanometer with a vacuum tube amplifier. Contacts at *A*, *B*, etc. are made with moist cotton.

DISCUSSION

If distilled water can leach materials out of the cell it would not be surprising if it eventually produced irreversible injury: this appears to be the case in exposures of 3 weeks or more in our experiments. In this connection we may recall the statements by various investigators that water distilled from apparatus consisting entirely of glass or quartz may be toxic.

It is of interest to inquire how the effects of distilled water on irritability are produced. Since the action current depends on the presence of an outwardly directed P.D. across the protoplasm⁸ it might

⁷ Blinks, L. R., *J. Gen. Physiol.*, 1929-30, **13**, 361.

⁸ Osterhout, W. J. V., *Biol. Rev.*, 1931, **6**, 369.

be supposed that this P.D. is lowered by the distilled water to a degree which makes the action current impossible.

We therefore measured this P.D. in the usual manner⁸ by placing Solution *A* at *C* and *D* and then killing *F* with chloroform and measuring the P.D. between *C* and *F* and *D* and *F*. Since this reduces the P.D. of *F* approximately to zero it gives a measure of the P.D. at *C* and *D*. This was on the average about 85 mv.

The measurement was repeated on other cells in which *C* had been treated with distilled water until irritability had disappeared. The P.D. of *C* was then found to be about 120 mv.

This rise in the P.D. across the protoplasm might be explained in various ways. If, for example, salts were leached out of the protoplasm so as to diminish the inwardly directed P.D. across the inner protoplasmic surface the outwardly directed P.D. across this surface (due mostly to potassium in the sap) would appear to increase, unless compensating processes occurred at the outer surface.

This would indicate that the chief effect of the distilled water is on the outer protoplasmic surface and the protoplasm and that the inner surface (adjoining the vacuole) still gives a marked P.D. due chiefly to the potassium in the vacuole.⁸

The action of distilled water on the outer surface of the protoplasm is evidently to leach something out.⁹ The nature of the substance will be discussed in a later paper. According to B. Hansteen Cranner¹⁰ and others¹¹ living cells of plants¹² when placed in contact with distilled

⁹ The result cannot be due to the slight change in osmotic pressure experienced in passing from Solution *A* to distilled water for the same result is obtained when the cells are transferred from pond water or from very dilute Solution *A* to distilled water.

¹⁰ Cranner, B. H., *Zur Biochemie und Physiologie der Grenzschichten lebender Pflanzenzellen*, Christiania, Grøndahl and Sønns, 1922. (Meldinger fra Norges Landbrukshøjskole, 1922, **2**, Nos. 1 and 2.)

¹¹ Grafe, V., *Biochem. Z.*, 1925, **159**, 445; 1929, **205**, 256; *Beitr. Biol. Pflanz.*, 1928, **16**, 129. Grafe, V., and Horvat, V., *Biochem. Z.*, 1925, **159**, 449. Grafe, V., and Magstris, H., *Biochem. Z.*, 1925, **162**, 366; 1926, **176**, 266; **177**, 16. Grafe, V., and Ose, K., *Biochem. Z.*, 1927, **187**, 102. Grafe, V., and Freund, K., *Beitr. Biol. Pflanz.*, 1928, **16**, 140. Magstris, H., *Biochem. Z.*, 1929, **210**, 85. Magstris, H., and Schäfer, P., *Biochem. Z.*, 1929, **214**, 440. Thierfelder, H., and Klenk, E., *Die Chemie der Cerebroside und Phosphatide*, Berlin, Julius Springer, 1930.

¹² In some cases at least no injury to the cells appears to be involved.

water regularly give off certain substances. They regard these as phosphatides but this identification is not confirmed by Steward.¹³

An alternative explanation might be that the supply of soluble calcium in the cell is decreased by metabolism so rapidly that it falls below the level needed for irritability unless continually renewed from without. This seems improbable in the short time required for these experiments and especially in view of the fact that we find no such deposits of calcium oxalate as occur in many plant cells.

The simplest assumption would appear to be that the cell manufactures one or more substances which may be called collectively *R*. This enters the surfaces and makes possible the normal irritability. In pond water¹⁴ or in Solution *A* this substance dissolves out very slowly so that it is replaced by the cell about as rapidly as it comes out but at certain times of the year the dissolving action becomes more rapid or the production of *R* is slower so that normal irritability disappears. When cells are placed in distilled water the leaching action is so rapid that the outer protoplasmic surface loses *R* more rapidly than it is acquired and in consequence the normal irritability is lost. This effect of distilled water may be largely due to the absence of calcium¹⁵ since we find that the addition of about 0.001 M CaCl₂ to distilled water prevents this effect. When irritability has been lost in distilled water it can be restored about as readily in 0.001 M CaCl₂ as in Solution *A*. This would be expected if we were dealing with the substances observed by B. Hansteen Cranner since he states that calcium prevents their solution. Loeb¹⁶ suggested that the protoplasmic surface resembles a soap which is made harder by calcium and softer by sodium and potassium. Other observers have noted specific effects of calcium on the protoplasmic surface.¹⁷

¹³ Steward, F. C., *Biochem. J.*, 1928, **22**, 268; *Brit. J. Exp. Biol.*, 1928-29, **6**, 32.

¹⁴ Cells transferred from pond water to distilled water act like those transferred from Solution *A* to distilled water.

¹⁵ Some of the other bivalent or trivalent cations would no doubt act somewhat like calcium.

¹⁶ Loeb, J., *The dynamics of living matter*, New York, The Columbia University Press, 1906.

¹⁷ Cf. Höber, R., *Physikalische Chemie der Zelle und Gewebe*, Leipzig, W. Engelmann, 6th edition, 1926, 696. Examples will be found in recent work on blastomeres and on microdissection.

In this connection we may recall the injurious effects of lack of calcium in all sorts of organisms, including the phenomena of antagonism. These may depend on the fact that an important function of calcium is to prevent the leaching out of substances from the surface. Apparently only a little calcium is needed for this purpose. A great excess of calcium may prove toxic by acting in some other way. A good illustration of this is found in *Halicystis* as described by Blinks.¹⁸ In sea water the cells show an outwardly directed P.D. of 60 to 80 mv. which quickly disappears when 0.6 M NaCl is substituted for sea water. But when 2.5 parts of 0.4 M CaCl₂ are added to 97.5 parts of 0.6 M NaCl the P.D., although falling at first, rises to nearly the normal value. In pure 0.4 M CaCl₂ on the other hand it drops approximately to zero and so continues.

It may be remarked in passing that the sap of *Valonia* contains little or no calcium¹⁹ but the sap is probably nearly saturated with R so that calcium is not needed to prevent leaching of R in the vacuole. Lack of calcium in the external solution soon produces injury.

The fact that anesthesia can be produced by removing something from the cell raises the question whether other cases of anesthesia may be explained in the same way. As a matter of fact one of the earliest theories of anesthesia, that of Bibra and Harless (1847) was precisely this;²⁰ *i.e.*, that chloroform and ether dissolved out certain substances from the brain.

It is of interest to find that reversible anesthesia can be maintained for a week at a time; this recalls the long periods of anesthesia possible with certain animals.²¹

¹⁸ Blinks, L. R., *J. Gen. Physiol.*, 1929–30, **13**, 223.

¹⁹ This seems to be the case with soluble calcium in many flowering plants according to analyses by the senior author. But according to Thoday and Evans (Thoday, D., and Evans, H., *Ann. Bot.*, 1932, **46**, 781) in certain plants soluble calcium and soluble oxalate may exist in different cells. When the sap is extracted mutual precipitation occurs. Hence the analysis will show less than the true amount of soluble calcium. See also Czapek, F., *Biochemie der Pflanzen*, Jena, Gustav Fischer, 3rd edition, 1925, **3**, 70.

²⁰ Henderson, V. E., *Physiol. Rev.*, 1930, **10**, 171.

²¹ Animals may be anesthetized for several days at a time without permanent injury, *e.g.* tadpoles (Overton, E., *Studien über die Narkose*, Jena, Gustav Fischer, 1901), frogs (Krogh, A., cited in Winterstein, H., *Die Narkose*, Berlin, Julius Springer, 2nd edition, 1926, 40; for experiments by Winterstein see *Biochem. Z.*, 1915, **70**, 130), and birds (Ellis, M. M., *J. Pharmacol. and Exp. Therap.*, 1923, **21**, 323).

In this connection we may state that in the late spring it is not uncommon to find cells in the ponds which cannot be stimulated electrically²² when brought into the laboratory. Apparently this condition may last for weeks in their natural environment. We are not able to change this by keeping them in Solution *A*. It would therefore seem that the difficulty is in the cells themselves which do not produce *R* in normal quantity at this season.

In conclusion we may emphasize that the term anesthesia is here employed, as often in nerve physiology, merely to denote lack of response to electrical stimulation: other effects were not investigated, except that it was noted that protoplasmic streaming continues after leaching with distilled water.

SUMMARY

Cells of *Nitella flexilis* Ag. lose their power to respond to ordinary electrical stimulation after 2 or 3 days in distilled water. It returns after a day or so when they are replaced in their normal environment, in a suitable nutrient solution, or in a dilute solution of CaCl_2 .

Here anesthesia seems to be produced by removing something from the cell and this raises the question whether other cases of anesthesia may be explained in the same way.

The antagonistic action of calcium, in some cases at least, appears to depend on its power to prevent substances from leaching out of the cell.

²² *I.e.* earlier in the season such cells can be stimulated by 50 to 160 mv. but in the late spring they cannot be stimulated by 300 mv. or even more.