

## RELAPSE PHENOMENA OF SPIRONEMA RECURRENTIS.

By HENRY EDMUND MELENEY, M.D.

*(From the Laboratory of Tropical Medicine, Department of Medicine, Peking Union Medical College, Peking, China.)*

(Received for publication, April 9, 1928.)

Our present knowledge of the interaction of host and parasite in relapsing fever may be summarized as follows.

At the time of the crisis which terminates the attack of fever, there is rapid agglutination and destruction of the spirochetes with the subsequent formation of immune bodies in the blood (Sawtschenko and Melkich (1); Novy and Knapp (2)). These substances are specific for the strain of spirochetes which was present during the preceding attack, but have no influence on the spirochetes of the succeeding relapse. The spirochetes of the relapse give rise, in turn, to immune substances which are specific for them but not for the spirochetes of the first attack (Levaditi and Roché (3); Jansco (4)). Some workers have encountered, in successive relapses, several modifications of the original strain of spirochetes (Kudicke and Feldt (5) ), while others have found only two alternating strains (Cunningham (6) ). During epidemics of relapsing fever, some investigators have found a remarkable uniformity in the strain causing the first attack (Jansco (4) ), while others have found several different strains (Toyoda (7) ). Passage through its natural intermediate host, the tick, has also been shown to produce a change in the serological reactions of the spirochete (Kroo (8) ). The new strains of spirochetes produced by relapses have been found by some workers to remain immunologically different from the spirochetes of the first attack through many animal passages (Levaditi and Roché (3); Cunningham (6) ), while others have described a gradual reversion to the original strain (Kudicke and Feldt (5); Toyoda (11) ). In mice which have apparently recovered from the infection, either naturally or by arsenical treatment, the brain and sometimes other organs are infectious for new mice for a period of several weeks (Buschke and Kroo, (9) ), and spirochetes have actually been found in very small numbers in the blood stream of patients during the interval between attacks (Kudicke, Feldt and Collier, (10) ).

### *Plan of Work.*

The present study was undertaken for the purpose of studying further the changes in serological reactions produced during the

relapses of *Spiroplasma recurrentis*. The animals used were the gray squirrel (*Sciurotamias davidianus*<sup>1</sup>) and the striped chipmunk (*Eutamias asiaticus*), both of which are native to North China. Chipmunks were used only when squirrels were not available. In both of these animals intraperitoneal inoculation of blood direct from a Chinese patient suffering from louse-borne relapsing fever produced a non-febrile attack lasting usually 3 to 5 days, in which huge numbers of

TABLE I.

*Typical Course of Relapsing Fever in a Splenectomized Squirrel (Sq. B, Chart 1).*

March 25. Splenectomy performed.

March 29. Inoculated intraperitoneally with 0.5 cc. whole blood from a positive squirrel.

	Dates inclusive	Duration in days	Result of examination of tail blood				
			1st day	2nd day	3rd day	4th day	5th day
First attack.....	Mar. 30-Apr. 3	5	++	+++	++++	+++	+++
First interval.....	Apr. 4-11	8	Daily examination negative for 8 days				
Second attack (1st relapse)...	Apr. 12-14	3	+	+	+++		
Second interval.....	Apr. 15-20	6	Daily examination negative for 6 days				
Third attack (2nd relapse)...	Apr. 21-25	5	+	+	++	++	+++

The number of plus signs indicates relative intensity of blood infection. + = one spirochete to ten or more fields. ++++ = 20 or more spirochetes to a single oil immersion field.

The tail blood was examined daily for 30 days after the third attack and was always negative.

spirochetes were present in the animal's blood. A second attack, however, never occurred, and the strain at first employed died out after the sixth transfer.

The observation of Tournade (12) that splenectomy increased the susceptibility of the wild rat to infection with *S. recurrentis* suggested that this procedure might produce relapses in squirrels and chipmunks,

<sup>1</sup> In a previous paper (13) this squirrel was erroneously called *Sciurus vulgaris*.

and this was found to be the case. The effect of splenectomy on the course of the disease has already been reported (13). Not only a second attack (first relapse) but a third attack (second relapse) occurred in many of the animals. Table I shows a typical course of infection in a splenectomized squirrel. Kritschewski and Rubinstein (14) have recently shown that splenectomy markedly increases the mortality of infection with *S. recurrentis* in white mice.

In the present experiments the original strain of spirochetes was transferred from squirrel to squirrel at the height of the first attack. When relapses occurred with this strain the relapse spirochetes were likewise transferred to separate series of squirrels. These squirrels,

TABLE II.  
*Duration of Existence of Strains Maintained by Transfer.*

Strain No.	Duration <i>days</i>	No. of transfers
I	132	38
II	106	29
III	98	26
IV*	75	20
IV†	32	8
Va††	54	16
Va§	39	10
Vb	50	14
VI	22	6

\* Isolated from Sq. C, Chart 1; † isolated from Sq. D, Chart 1; †† isolated from Sq. F, Chart 1; § isolated from Sq. E, Chart 1.

in turn, usually had relapses, and when this occurred the spirochetes appearing in the relapses were tested against the monovalent immune sera produced by previously isolated strains. Whenever a strain of spirochetes was encountered which could not be agglutinated by any of these sera it was considered to be a new strain and was preserved by transfer into new squirrels.

By this method six strains of spirochetes were isolated, which retained their specific agglutinating characteristics during the period of our observations, extending from March 21, to July 30, 1927. Table II shows the duration of existence of the six strains. The history of these strains is given in detail below.

### *Technique.*

*Splenectomy.*—This was performed under ether anesthesia through a small transverse incision below the left costal margin. The pedicle was ligated, and the wound closed with silk sutures and metal clips. A localized area of necrosis frequently developed about the tail of the pancreas where this had been accidentally ligated. Very few animals died as a direct result of the operation, and general peritonitis did not occur.

*Transfer of Spirochetal Blood.*—Infection of the first squirrels was accomplished by the intraperitoneal injection of venous blood from a human case of relapsing fever. For transfer from squirrel to squirrel, blood was taken from the heart or the saphenous vein. 0.5 cc. of blood from an animal with a moderately heavy infection usually produced demonstrable blood infection within 12 to 18 hours.

*Examination of Blood for *S. recurrentis*.*—The tail blood of all infected animals was examined daily by dark-ground illumination. No animal was declared negative without a search of at least 5 minutes.

*Collection of Immune Sera.*—Blood was taken from the saphenous vein or by heart puncture. The sera were pipetted off from the clot and stored in the refrigerator. Sera appeared to retain their original agglutinative titer for over 2 months, that is, until the present study was completed.

*Agglutination Tests.*—Preliminary tests suggested that a dilution of less than 1-50 sometimes produced non-specific agglutination. This dilution was the lowest used in differentiating strains of spirochetes, but in measuring the curve of agglutinins in single animals dilutions of 1-10 and 1-20 were also used. Sera were diluted with normal saline, and controls consisting of saline and negative sera were employed. For the spirochete suspension the tail blood of strongly positive squirrels was used. This was found to be more practical than the removal of blood into citrate solution and the subsequent removal of the red blood cells, because the latter procedure sometimes led to the rapid death or spontaneous agglutination of the spirochetes. With moderate or large numbers of spirochetes in the blood, the red blood cells did not interfere with the reading of the tests. Tests were performed with slide-cover slip preparations and observations were made at once by dark-ground illumination. A second observation after half an hour was found to be of no value. This technique is practically the same as that employed by Cunningham (6).

### *History of Strains Isolated.*

The original strain of spirochetes used for these observations was obtained from a Chinese woman suffering from relapsing fever in her first attack of fever. 4 cc. of whole blood were injected intraperitoneally into a squirrel (Squirrel A, Chart 1). This squirrel's spleen had been removed 5 months previously. Spirochetes appeared in the

CHART 1.

*Lineage of Strains Isolated.*

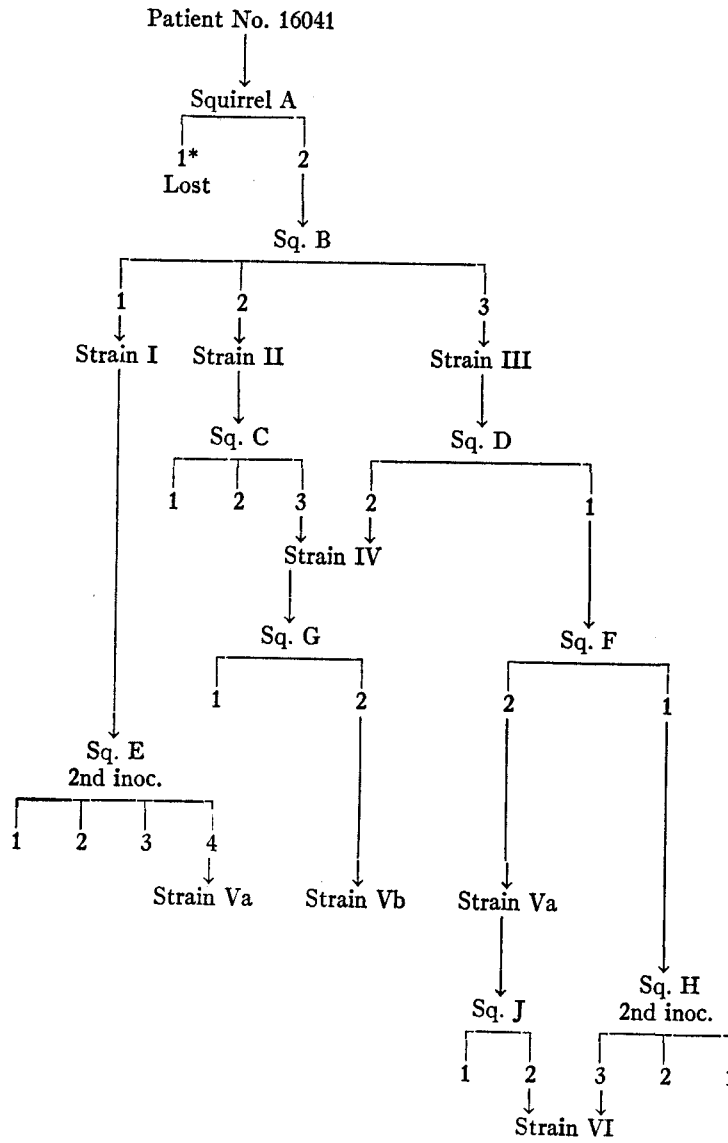

\* Arabic numerals refer to attacks.

tail blood the day following inoculation and the attack lasted 5 days. It happened that no new squirrels were available at this time, so that the spirochetes of this attack were lost. After a negative interval of 7 days, spirochetes again appeared in the tail blood. This second-attack (first-relapse) strain of spirochetes was thereafter maintained in squirrels by transfer during their first attack, and became Strain I in the following experiments.

Chart 1 shows the lineage of the strains isolated. It has been reduced to the simplest possible form by omitting all animals except those from which new strains were isolated. It will be seen that Strains II and III originated from the second and third attacks, respectively, of a squirrel (Sq. B) inoculated with Strain I; that Strain IV was obtained from two sources, namely from the third attack of a squirrel (Sq. C) inoculated with Strain II and from the second attack of one (Sq. D) inoculated with Strain III. Strain V is divided into two closely related substrains, Va and Vb. Strain Va was obtained both from a fourth attack<sup>2</sup> in a squirrel (Sq. E) inoculated with Strain I and from a second attack in one (Sq. F) inoculated with Strain III. Strain Vb appeared in the second attack of a squirrel (Sq. G) inoculated with Strain IV. At first all of the Strain V spirochetes appeared to be identical, since they were each agglutinated by the monovalent serum produced by the other. It was found, however, that the spirochetes designated as Strain Vb had a definite relationship with Strain III, while those designated as Strain Va failed to show this relationship but did show a relationship to Strain II (see later section on Relationship of Strains). Finally Strain VI originated from the third attack of a squirrel (Sq. H) inoculated with Strain III and from the second attack of a squirrel (Sq. J) inoculated with Strain Va. It was necessary to close the present study soon after the isolation of Strain VI, because of inability to secure more animals.

#### *Sequence of Strains.*

A consideration of the sequence in which the different strains of spirochetes appeared in relapses is important. The identity of each relapse strain was determined either by testing the spirochetes which

<sup>2</sup> The last three of these attacks were produced by a second inoculation with Strain I.

appeared during an attack against monovalent immune sera, or by observing what additional agglutinins appeared in the animal's blood after the attack. In some cases both procedures were used. Tests of an animal's serum after an attack did not always indicate clearly what strain had been present during the attack, for agglutination was sometimes equally strong with the sera of two different strains. This is because of the relationship existing between certain strains, as will be shown later. Table III contains those cases in which there was a clear-cut indication of the sequence. It will be seen that in animals inoculated with Strain I, Strain II was the only strain which appeared in the second attack, and Strain III the only one which appeared in the third attack. When other strains were inoculated, however, the sequence was not so uniform. Strain II was usually followed in the

TABLE III.  
*Sequence of Strains in Relapses.*

Strain inoculated	Number of cases in which each strain appeared in subsequent attacks (relapses)													
	Second attack strain							Third attack strain						
	I	II	III	IV	Va	Vb	VI	I	II	III	IV	Va	Vb	VI
I	0	9	0	0	0	0	0	0	0	4	0	0	0	0
II	1	0	7	0	0	0	0	0	0	0	2	1*	0	0
III	0	0	0	2	1	0	0	0	0	0	0	0	0	1
IV	0	1	2	0	0	3	0	0	0	0	0	0	0	1
Va	0	0	1	0	0	0	1							

\* Immune serum of this squirrel agglutinated spirochetes of both Strains Va and Vb.

second attack by Strain III, but once there was a recurrence to Strain I, and in the third attack Strain IV appeared twice and Strain V once. Strain III was followed in the second attack by Strain IV or Va, showing similarity here to the third attack after inoculation with Strain II. Strain IV was followed in the second attack three times by Strain Vb, twice by Strain III and once by Strain II. Strain Va was followed once by Strain III and once by Strain VI. Strain VI appeared also in the third attack once after inoculation with Strain III and once after inoculation with Strain IV. In short, inoculations with Strain I gave a uniform sequence, while after inoculations with other strains

the sequence of strains was not uniform. In some cases reversion to earlier strains occurred, while in other cases new strains appeared.

Although the figures presented in Table III are small for most of the strains, they are sufficient to illustrate an important principle connected with the development of relapses. This principle is the relationship of strains, on the basis of which all except one of the sequences which are shown in Table III can be explained. This relationship between certain strains will now be considered.

*Relationship of Strains.*

Cunningham (6), in his experiments with squirrels in Madras, India, was able to isolate only two strains of spirochetes, and these strains alternated in their appearance. Whenever his Strain I was inoculated Strain II appeared in the relapse, and whenever Strain II was inoculated Strain I appeared in the relapse. In the present work,

TABLE IV.  
*Agglutinins in Serum of Squirrels after First Attack.*

Strain inoculated	No. of sera tested	No of sera containing agglutinins in 1-50 dilution for strains			
		I	II	III	IV
I	10	10	0	0	0
II	11	0	11	0	0
III	5	3	0	5	0
IV	7	0	2	0	7

although the strains already described were definitely distinct, certain relationships were found to exist which correspond in principle with Cunningham's findings.

These relationships were demonstrated by the agglutination tests performed with sera taken from animals after the completion of one or more attacks. Table IV shows the results of agglutination tests performed with sera taken after the first attack of Strains I, II, III and IV. It will be noted that, in the case of serum from Strains I and II, agglutinins were demonstrated only for the homologous strain of spirochetes. In the case of Strain III, however, three out of five animals developed agglutinins not only for Strain III but also for



Strain I. Similarly in the case of Strain IV, two animals out of seven developed agglutinins for Strain II as well as for Strain IV. This indicates a relationship between Strains I and III and between Strains II and IV.

The relationship between Strains I and III is further demonstrated by studying the agglutinins developed after the second attack in squirrels inoculated with Strain II. The results of these tests are shown in Table V. It will be seen that nine of the ten sera tested still possessed the agglutinins for Strain II which they had acquired as a result of the first attack. As a result of the second attack, all ten of the sera contained agglutinins for Strain I and five of them possessed in addition agglutinins for Strain III. There was more uniformity of agglutinin formation for Strain I than for Strain III, although, as has been shown already in Table III, the Strain III

TABLE V.  
*Agglutinins in Serum of Strain II Squirrels after Second Attack.*

No. of sera tested	No. of sera containing agglutinins in 1-50 dilution for strains			
	I	II	III	IV
10	10	9	5	0

spirochetes appeared more often than Strain I in the second attack of squirrels inoculated with Strain II.

Strain Va was found to be related to Strain II, by the fact that after a first attack with Strain Va the animal's serum in two cases out of three agglutinated both the Strain II and the Strain Va spirochetes.

A relationship was shown to exist between Strain III and Strain Vb, by the fact that the Strain III spirochetes were agglutinated by univalent Strain Vb serum in all of the seven cases where the test was performed. Strains III and Vb were not identical, however, since the Strain Vb spirochetes were never agglutinated by univalent Strain III serum.

Strain VI was isolated such a short time before the close of the study that its relationship to other strains could not be investigated by means of agglutination tests.

In recapitulation it may now be stated that relationships were shown by agglutination tests to exist between Strains I and III, between Strains II and IV, and II and Va, and between Strains III and Vb. If one refers again to Table III it is evident that these relationships are all between strains which occurred, or might theoretically occur, in alternate attacks. If we now apply this observation to Strain VI in an attempt to ascertain its relationship to other strains, it appears (Table III) that this strain was related both to Strain III and to Strain IV, since it was responsible for the third or alternate attack in animals inoculated with each of these strains. Strains which were found to be related to one another did not occur in consecutive attacks, except once, when Strain II spirochetes appeared in a first relapse of Strain IV.

*Reinoculation Experiments in Non-Splenectomized Squirrels.*

Twenty-four squirrels were inoculated without removing the spleen and had no relapse. After an interval of 10 to 20 days, each one was reinoculated with the strain with which it had been infected originally. All except one showed itself immune, the tail blood remaining negative after the reinoculation. Following this, other strains were inoculated in succession, with shorter intervals between inoculation. The inoculations were usually successful, producing a blood infection lasting from 1 to 5 days. No squirrel, however, became infected with more than four strains. Among the twenty-four squirrels in this series, the results were as follows: 6 squirrels became positive to 4 different strains, 11 squirrels became positive to 3 different strains, 6 squirrels became positive to 2 different strains, and 1 squirrel became positive to 1 strain only.

The successful inoculation of as many as four different strains in succession emphasizes the individuality of these strains. The reinoculations were made at such short intervals that loss of immunity cannot be held responsible for the successful reinfections, for it is usual for antibodies against a given strain to be demonstrable in an animal's blood for at least a month after an attack with that strain. The following protocol illustrates this type of experiment.

*Protocol.*—Squirrel 1. Spleen not removed. Inoculated with Strain I. Tail blood positive for 3 days. After 16 days negative the squirrel was reinoculated with Strain I. Tail blood negative for 4 days. Then it was inoculated with

Strain II. Tail blood positive for 2 days. After 9 days negative, it was reinoculated with Strain III. Tail blood positive for 2 days. After 5 days negative, it was reinoculated with Strain IV. Tail blood positive for 3 days. Total interval from second inoculation with Strain I to inoculation with Strain IV, 22 days.

The agglutinins and protective immune substances which were developed by a single attack seemed to be about equal in strength in normal and in splenectomized squirrels. Reinfection with a previously inoculated strain was successful only once in a normal and once in a splenectomized animal. Agglutinins to a titer of 1-12,800 frequently developed in the serum of both normal and splenectomized animals. The strength of the agglutinins seemed, in general, to be directly proportional to the intensity and duration of the attack. It may be stated that neither specific immunity nor agglutinin formation seemed to be influenced by the presence or absence of the spleen.

#### DISCUSSION.

##### *A. Strain Relationships, Relapses and Cure.*

The fact that the strains of spirochetes which appeared spontaneously in consecutive attacks in splenectomized squirrels did not (with one exception) appear to be serologically related to each other, while those which appeared in alternate attacks were so related, is explainable on the basis that, at the close of an attack, the spirochetes find themselves in an exceedingly unfavorable environment, in which only those can survive which possess, or can quickly develop, biological affinities most different from those of the original strain. These biologically different spirochetes produce the second attack, at the close of which they themselves encounter a very unfavorable environment. Again only those can survive which possess, or can quickly develop, biological affinities which are very different from the second strain. Since the unfavorable conditions which were present at the close of the first attack probably still exist at the end of the second attack, the original strain cannot again appear, but a third strain of spirochetes does appear, whose biological affinities are more like those of the original strain than like those of the first-relapse strain. Assuming that a few organisms survive in the brain and blood stream even after the last attack, a fact which Buschke and Kroo (9) and Kudicke, Feldt and

Collier (10) have established, it is probable that clinical cure occurs when the surviving spirochetes find their environment too unfavorable for further multiplication in any great number.

The question arises whether the spirochetes which survive after an attack already possess biological affinities different from the original strain before they meet the unfavorable conditions which cause the destruction of their fellows, or whether their biological affinities change as a result of the unfavorable environment. The evidence at hand seems to indicate that the change does not occur before the development of the unfavorable environment but is rather the result of it; for if spirochetes which were biologically different from the original strain had existed before the crisis, one would expect them to have multiplied parallel with the original strain and to have given rise to antibodies in demonstrable amount, which they did not do.

The number of attacks which will occur before the medium becomes too unfavorable for the further occurrence of relapses must depend upon the interplay of several biological factors. Among these the three following are important:

(1) *Differences between Types of Spirochetes*.—It is well known that in the tick-borne type of human relapsing fever, the attacks are more numerous, are of shorter duration and occur at shorter intervals than in the louse-borne disease. The shorter attacks are probably due to a biological difference in the parasites, while the shorter intervals and larger number of attacks may be due, in part at least, to a less intense stimulation of immune bodies in the host as a result of the shorter attacks.

(2) *Susceptibility of Host*.—Certain animals like the guinea pig are naturally refractory to infection with *S. recurrentis*. Others, like the species of squirrel used in these experiments, normally have one attack but no relapse. Man is the ideal host and usually has the largest number of relapses.

(3) *The spleen* apparently plays an important rôle in preventing a multiplication of the parasites in animals like the wild rat which are naturally refractive to infection (Tournade (12)). It also prevents relapses in moderately susceptible animals like the Chinese squirrel. The exact nature of this protection is at present unknown, but the above observations indicate that it is not of the same nature as the

specific immune bodies which are produced in response to the infection. Two facts support this conclusion. In the first place, non-splenectomized animals could usually be reinfected by the inoculation of a second strain of spirochetes, although a spontaneous relapse never occurred in them. This indicates that the spleen did not produce any wider range of immune bodies in normal animals than in splenectomized animals. It also indicates that the protective power of the spleen is relatively slight, since a second attack which would not occur spontaneously could be produced by massive reinoculation. In the second place, splenectomized animals developed as efficient an immunity and as strong agglutinins against the organisms which appeared in their blood as did non-splenectomized animals. This indicates that the protection afforded by the spleen is not due to its production of specific antibodies. Further light on the protective function of the spleen might be obtained by determining whether, at the close of the first attack in animals which do not have a relapse, the spirochetes are all killed; or whether a few survive as they do in animals which have relapses. If they are all killed, the spleen would seem to assist in their destruction, whereas if they persist over a considerable period of time, it would appear that the spleen merely has the power to inhibit their multiplication.

#### *B. Zones of Antibody Formation.*

It will be recalled that when Strain III, IV or V was inoculated into an animal, serum taken after the first attack often agglutinated not only the strain of spirochetes inoculated, but also a related strain. When Strain I or II was inoculated, however, serum taken after the first attack agglutinated only the strain inoculated. To understand this, one must remember that the designation of any strain of organisms as Strain I is entirely arbitrary, and that it simply means that one does not possess any preceding strain. Our Strain I was a first relapse spirochete from a squirrel which had been inoculated from a patient. We know that a change of strain must have taken place in the squirrel. Another change may have taken place in the louse which transmitted the disease to the patient, and it is possible, also, that the louse acquired its spirochetes from another human being during a relapse. If we had possessed all of these preceding strains of spiro-

chetes, it is reasonable to suppose that some of them could have been agglutinated by sera taken after the first attack with our Strain I or Strain II. There is no reason to suppose that Strains I and II were not capable of giving rise to as wide a range of antibodies as the other strains which were isolated in these experiments. This fact is emphasized because it is important in considering the serological reactions in any group of spirochetes, and has apparently been overlooked in much of the preceding work on relapsing fever.

There is another conception, however, which may explain why our Strain I spirochete was sometimes agglutinated by monovalent Strain III serum, whereas our Strain III spirochete was never agglutinated by monovalent Strain I serum. When Strain III originally developed in the third attack of an animal inoculated with Strain I, it developed in the presence of antibodies which would destroy any Strain I spirochetes which might appear. However, when these Strain III spirochetes were inoculated into a new animal which possessed no antibodies against Strain I, spirochetes of the closely related Strain I which might develop during the first attack would not be destroyed, but would multiply along with the Strain III spirochetes, and give rise, at the end of the attack, to Strain I antibodies in serum which was supposedly monovalent for Strain III. If this conception is correct, one must assume that, since Strain I spirochetes were agglutinated by some Strain III sera but not by others, the Strain I spirochetes developed in some animals inoculated with Strain III but not in others.

Kudicke and Feldt (5) found that a component of their Strain I (Ausgangsstamm) developed in their relapse strains when these were passed through normal mice, and that this component increased in subsequent passages until the relapse strains ultimately reverted completely to their Strain I. In the present study, no reversion to an older strain was observed. The development of agglutinins for older, closely related strains was the only approach to such a reversion. Each strain possessed the same agglutination reactions at the end of our study as it had after its first transfer to a new squirrel. This coincides with the observations of Cunningham (6), who also worked with squirrels. Toyoda (11), on the other hand, who worked with mice, found that his relapse strain reverted to the original strain after

eighteen passages. Whether the type of experimental animal had anything to do with this difference in results is a question which deserves further investigation.

It seems probable that each strain of spirochetes which appears during an attack of relapsing fever contains its own peculiar group of components, the exact range of which depends largely upon the range of the antibodies which were present in the environment in which the strain originated. When a number of relapse strains are isolated in experimental animals by artificial transfer, it is apparent that the components making up those strains may overlap to a considerable degree.

Fig. 1 has been constructed in order to illustrate the relationships of our strains and the gradual increase in the complexity of their sero-

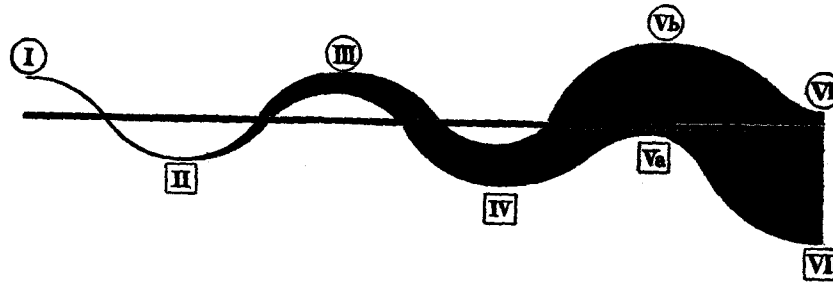

FIG. 1. The broadening zone of strain relationships in the descendants of Strain I.

logical relations. The wavy form of the curve represents the alternation in serological relationships between the spirochetes which appeared in consecutive attacks. The strains above the base line and enclosed in circles were related to each other, and those below the base line and enclosed in squares were likewise related. The curve is linear as far as Strain II because the sera produced by Strains I and II failed to agglutinate any other strains. The gradual broadening of the curve beginning just beyond Strain II, until it ultimately extends both above and below the base line at Strain V, represents the gradually broadening zone of relationship among the strains which were descendants of Strain I. The curve must be broader at III than at I because Strain III sometimes included a Strain I component, but was not identical

with Strain I. At V the curve must extend both above and below the base line, because Strain Vb was related to Strain III, while Strain Va was related to Strain II. At VI the curve must also extend both above and below the base line, because, since Strain VI appeared as the third-attack spirochete both in an animal inoculated with Strain III and in one inoculated with Strain IV, it was apparently related to both of these strains.

It is probable that a similar curve could have been constructed if the work had been begun either with an earlier strain than Strain I or with one of the later strains, say Strain V. In the former case the curve would show broader relationships in the region of the present Strain I, perhaps carrying it both above and below the base line. In the latter case, on the other hand, the curve would be linear for the distance from Strain V to Strain VI where it is now broadest.

There is evidence that a number of strains of *S. recurrentis* are present among human cases in an endemic region like North China. While the present work was in progress two other human cases yielded strains of spirochetes which could not be agglutinated by any of our sera. The components making up these strains evidently did not include any of those which made up our strains. Toyoda (7) also found that among ten cases of relapsing fever in a Manchurian mine there were at least three different strains of spirochetes. How many different immunological strains of *S. recurrentis* there may be in China, or in the entire territory where the louse-borne relapsing fever is found, could be determined only by the collection and testing of organisms from a very large number of cases from various regions.

The serological studies of many previous workers, as well as the present experiments, have demonstrated that agglutination and immunity tests are not satisfactory criteria for differentiating the spirochetes of relapsing fever from various parts of the world. Until some better criterion for their differentiation appears, it is reasonable to consider that all the spirochetes of relapsing fever belong to one species, *S. recurrentis*. Within this species there are two biological varieties, the louse-borne parasite, which everywhere produces relatively long attacks separated by long intervals in human beings, and which is difficult to transfer to white rats and mice; and the tick-borne parasite, which produces short attacks separated by short intervals in human



beings, and which is easily transferred to white rats and mice. The erection of several species, because of geographical or immunological differences, or differences between vectors, seems to be unwarranted.

#### SUMMARY AND CONCLUSIONS.

1. Squirrels and chipmunks were found to be susceptible to infection with the *Spironema recurrentis* of North China, but no relapses occurred in normal animals.

2. Splenectomy caused an increase in the intensity of the infection and the appearance of one or two relapses.

3. By inoculating splenectomized squirrels with a single human strain of spirochetes, six different strains were produced as a result of relapses.

4. The strains all retained their specific agglutinating characteristics during the period of observation. The oldest strain was observed for 132 days and through 38 transfers, the strain last isolated for 22 days and through 6 transfers.

5. The sequence of strains in relapses was not always the same. Sometimes new strains were produced, at other times there was reversion to an older strain.

6. Certain relationships between strains were established. The related strains were always those which appeared, or theoretically might have appeared, in alternate attacks. In only one case did related strains appear in two consecutive attacks.

7. Squirrels whose spleens were not removed had only one attack and developed immune substances only against the strain inoculated or against closely related strains. It was possible by reinoculation to produce infection in such squirrels with as many as four different strains in succession.

8. The spleen has a protective influence against the development of the relapse in the squirrel, but apparently does not control the formation of specific immune substances.

9. An explanation of the clinical course of relapsing fever is suggested on the basis of the observations recorded.

10. There is, at present, no justification for the division of the spirochetes of relapsing fever into different species.

The writer is indebted to his colleagues, Doctors, C. U. Lee, Samuel Zia and E. G. Nauck, for assistance in various parts of this work, and also to his Chinese technicians, without whose conscientious cooperation the work could not have been performed.

## BIBLIOGRAPHY.

1. Sawtschenko and Melkich, *Ann. Inst. Pasteur.*, 1901, xv, 497.
2. Novy, F. G., and Knapp, R. E., *J. Infect. Dis.*, 1906, iii, 291.
3. Levaditi, C., and Roché, J., *Compt. rend. Soc. biol.*, 1907, lxii, 815.
4. Jansco, N., *Z. Bakt., 1. Abt., Orig.*, 1918, lxxxi, 457.
5. Kudicke, R., and Feldt, A., *Arb. Staatsinst. exp. Therap. u. Georg Speyer-Hause*, 1921.
6. Cunningham, J., *Tr. Roy. Soc. Trop. Med. Hyg.*, 1925, xix, 11.
7. Toyoda, H., *Kitasato Arch. Exp. Med.*, 1919, iii, 43.
8. Kroo, H., *Klin. Woch.*, 1925, iv, 1355.
9. Buschke, A., and Kroo, H., *Klin. Woch.*, 1922, i, 2323.
10. Kudicke, R., Feldt, A., and Collier, W. A., *Z. Hyg. u. Infektionskrankh.*, 1924, cii, 135.
11. Toyoda, H., *Kitasato Arch. Exp. Med.*, 1920, iv, 40.
12. Tournade, A., *Compt. rend. Soc. biol.*, 1911, lxxi, 267.
13. Meleney, H. E., *Abhandlungen aus dem Gebiete der Auslandskunde*, Hamburgische Universität, Hamburg, 1927, xxvi, medical volume ii, pp. 328-332 (Festschrift für Dr. Nocht).
14. Kritschewski, I. L., and Rubinstein, P. L., *Z. Immunitätsforsch.*, 1927, li, 27.