

PHOTORECEPTOR STRUCTURES*

III. DROSOPHILA MELANOGASTER

By J. J. WOLKEN, PH.D., J. CAPENOS, AND A. TURANO

(From *Biophysical Research, Laboratory Photobiology, Eye and Ear Hospital and University of Pittsburgh School of Medicine, Pittsburgh, Pennsylvania*)

PLATES 134 TO 138

(Received for publication, December 27, 1956)

As a part of a comparative study of plant and animal photoreceptor structures we have been investigating the spectral response and structure of the compound eye of the insect *Drosophila melanogaster* (14). The compound eye of *Drosophila* is composed of approximately 700 ommatidia with each ommatidium consisting of seven retinula cells radially arranged forming a cylinder. Each retinula cell has a differentiated structure, the rhabdomere. Since the earliest investigations (5, 6) the rhabdomeres have been considered the "light trapping" area where the visual process is initiated. In three eye color mutants, scarlet, wild-type red, and white, we have found that the action or effectiveness spectrum is indicative of a pigment absorbing at 508 m μ , similar in absorption spectra to the visual complexes found in the vertebrate photoreceptors, but not similar in absorption spectra to any of the eye pigment extracts isolated from these mutants (14). We have assumed that the extractable pigments are from the sheath of pigment cells surrounding each ommatidium and that the action spectrum is indicative of a "visual" pigment, not as yet isolated or identified, residing within the rhabdomeres. Recent electron micrographs of the ommatidia in the house fly (3) as well as our own electron microscopic studies indicate a general "fine structure" within the rhabdomeres not too unlike the vertebrate retinal rods and cones (2, 7, 12, 14). We have, from the electron microscopic and pigment studies of a variety of photoreceptors, hypothesized a general geometrical fine structure for a photoreceptor in which the pigment molecules are oriented as monolayers at the aqueous protein and lipoprotein interfaces and are complexed with proteins or lipoproteins (12-14). In addition, *Drosophila* exhibits orientation relative to the direction of vibration of polarized light. The sensitivity to plane polarized light suggests the existence of a polarized light analyzer within the eye (9,

* This work was supported by grants from the National Council to Combat Blindness, Inc. (175-C), and the Institute of Neurological Diseases and Blindness of the National Institutes of Public Health (B 397 C2).

10), and recent research suggests a differential structural arrangement within each ommatidium (1).

It is with these considerations in mind that we have attempted by electron microscopy a structural analysis of the retinula to better understand its functioning within the ommatidium.

Experimental Methods

Scarlet (st), wild-type red (Canton special) and white (w) eyed adult *Drosophila melanogaster* were used in these studies. All flies were grown on cream of wheat-molasses medium (8) in a temperature-controlled room, $25^{\circ} \pm 2^{\circ}\text{C}$. The flies were decapitated (under a binocular microscope using a fine scalpel) and the heads immediately fixed in 1 per cent osmium tetroxide buffered with acetate-veronal to pH 7.5. Fixation was carried out for 4 hours, dehydration was in ethanols, and the specimens were embedded in *n*-butyl methacrylate polymerized at 45°C . overnight. The best fixation was obtained when the flies were collected and fixed within 4 hours after they had emerged from the pupae case. Sections, using fractured-glass knives, were cut of the order of 500 to 800 Å thick as could be determined from their interference colors, on a Porter-Blum microtome, for electron microscopy. No orientation of the ommatidia with respect to the angle of cutting could be achieved and therefore all sections were cut at random. All sections studied were examined in a Philips EM 100 electron microscope.

OBSERVATIONS

All of the *Drosophila* eye mutants studied by electron microscopy were found to have an ommatidium consisting of seven centrally located rhabdomeres, seven adjacent retinula cells, a distal cone and lens, and a sheath of pigment cells which extend the entire length of each ommatidium (14). The pigment sheath was not found in the white eyed (w) mutant. A longitudinal section of an ommatidium is illustrated in Fig. 10 *a* and diagramed in Text-fig. 1 *a*. Figs. 1 to 10 are electron micrographs, illustrating some of our observations of the retinula cells, particularly the fine structure within the rhabdomeres.

In cross-section (Fig. 1), the seven retinula cells are radially arranged, each having a medial portion extending toward the center of the ommatidium and terminating in a dense, circular rhabdomere. The rhabdomeres are situated in a relatively clear central cavity which is probably filled with a fluid. Each rhabdomere is distinct with respect to the retinula cell, there being a finely differentiated line of attachment between the rhabdomere and retinula cell. Fig. 2 represents at higher magnification, the central cavity and complete rhabdomere complement of another ommatidium cut in cross-section. A definite lamellar "fine structure" is observable within each of the rhabdomeres. This structure, also seen at a higher magnification in Fig. 5 (also Text-fig. 1 *b*), consists of parallel dense bands ~ 100 Å thick with less dense interspaces ~ 300 Å thick extending across the rhabdomere in a direction normal or approximately normal to the rhabdomeres' line of attachment to the retinula

cell. These dense laminations originate at the line of attachment and terminate in a scalloped border on the medial side of the rhabdomere, indicating that the lamellar structure probably represents double-membraned plates or

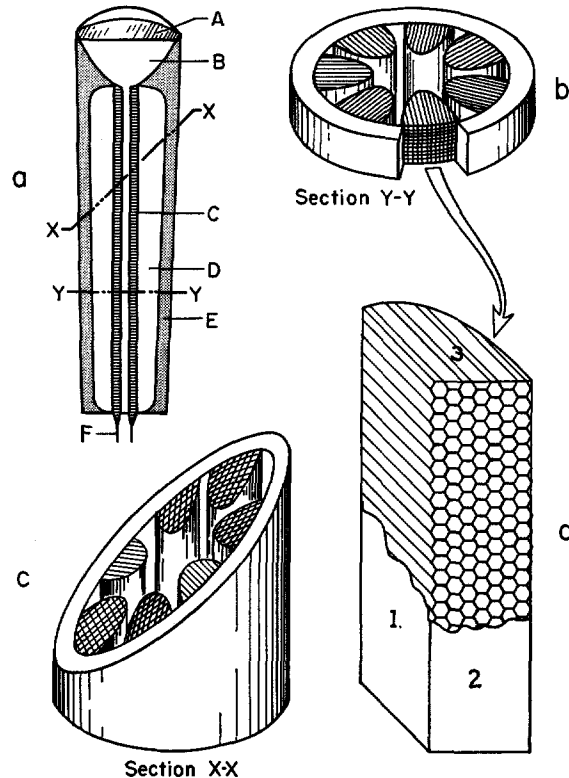

TEXT-FIG. 1. Diagrammatic section through an ommatidium.

(a). A longitudinal section of a complete ommatidium showing lens (A), cone area (B), rhabdomere (C), retinula cell (D), pigment sheath (E), and nerve fiber from the retinula cell (F). Cross-section cut Y-Y; oblique section cut X-X.

(b). A three-dimensional cross-section (Y-Y) through the ommatidium showing the lamellar pattern in all of the radially arranged rhabdomeres. The rhabdomere area has been enlarged at the expense of the retinula cells and the pigment sheath. The undifferentiated ring surrounding the rhabdomeres represents both the retinula cell area and the pigment sheath.

(c). Three-dimensional oblique section (X-X) through the ommatidium.

(d). Three-dimensional section of a rhabdomere. Two sides are cut away producing (1 and 3) a lamellar structure and (2) a hexagonal structure.

tubules, that are closely packed and extended away from the retinula cell toward the center of the ommatidium.

In all cross-sections the lamellar pattern is found, while a reticular struc-

ture, not seen in cross-sections, is found in some oblique and longitudinal sections of the rhabdomeres. The reticular structure is seen in Fig. 4 to consist of a uniform framework of dense bands and less dense interspaces. The dense bands measure ~ 100 A in thickness and the circular interspaces are ~ 400 A in diameter. Rhabdomeres which show the reticular structure have no differentiated line of attachment to the retinula cell. A combination of the reticular and lamellar structures are also observed and illustrated in R_1 of Fig. 6 and R_3 of Fig. 7. In this lamellar-reticular structure, the less dense interspaces are slightly elongated and arranged in parallel rows with the denser area between each row being almost continuous from one side of the rhabdomere to the other and giving the rhabdomere a faintly lamellar appearance.

In oblique sections (Fig. 3 and Text-fig. 1 *c*) the ommatidium presents an elliptical outline, and a characteristic distribution of the fine structural detail is observed. Those rhabdomeres which have their line of attachment more nearly parallel to the longest diameter of the ellipse have the lamellar pattern of fine structure while those rhabdomeres attached at the ends of the longest diameter, having their line of attachment more nearly parallel to the shortest diameter of the ellipse, have the reticular pattern of fine structure, as illustrated in Fig. 8, an extremely oblique section. Similar structures are observed in longitudinal sections (Figs. 6 and 7). The central rhabdomere in these sections has no laterally attached retinula cell and shows the reticular network, while the rhabdomeres on either side of it have the lamellar or lamellar-reticular structure. Rhabdomere R_3 in Fig. 6 has a lamellar structure and a differentiated line of attachment to the retinula cell, while rhabdomeres R_1 and R_2 illustrate lamellar-reticular structure without a differentiated line of attachment.

All rhabdomeres measured averaged 60μ in length and 1.2μ in diameter. The number of dense bands per rhabdomere averaged 23 per micron with an average thickness of 120 A.

DISCUSSION

The lamellar and reticular fine structures within the rhabdomeres of a single ommatidium, at first suggest the presence of two different structures within the rhabdomeres. However, the consistent occurrence in cross-sections, oblique sections, and longitudinal sections, regardless of the orientation of the eye with respect to the plane of cutting, indicates a single geometrical structure which produces two different general patterns in thin section depending entirely upon the orientation of the individual rhabdomere with respect to the plane of cutting. The fact that the dense bands and less dense interspaces are of the same order of magnitude in both the lamellar and the reticular design suggests a single structural packing. Each rhabdomere as

indicated by these observations appears to consist of double membrane tubes ~ 500 Å in diameter that arise at the medial border along the entire length of the retinula cell and project toward the center of the ommatidium. The tight packing of these tubes or rods produces a roughly hexagonal structure (Text-fig. 1 *d* and Fig. 10 *d*). Those planes of cutting which are parallel to the plane of projection of the rods or tubes give a lamellar structure, while the planes of cutting which intersect the rods or tubes obliquely or perpendicularly give a reticular or lamellar-reticular structure.

A cross-sectional cut through the ommatidium produces the lamellar pattern in all the rhabdomeres since this plane of cutting is parallel to the rods or tubes in all the rhabdomeres. However, a cut which passes obliquely through the ommatidium is only parallel to those tubes which are parallel to the shortest diameter of the ommatidium, while it is oblique to all other tubules. This differential effect of the plane of cutting in oblique sections is responsible for the characteristic distribution of structural design (Fig. 3 and Text-fig. 1 *c*). A similar differential effect in longitudinal sections is produced where the plane of cutting intersects perpendicularly the rods or tubes of the central rhabdomere, while it is less than perpendicular and sometimes even parallel to the rods or tubes of the other rhabdomeres (Figs. 6 and 7). A three-dimensional section of a rhabdomere was constructed from the electron micrographs (Fig. 10 *d*) by fitting together three surfaces to illustrate a single structural unit of packed rods as schematically diagramed in Text-fig. 1 *d*. This "fine structure" for the rhabdomere was found in all three of the eye mutants studied.

The rhabdomere is a layered structure with at least two surfaces available per layer, and if we assume that the pigment molecules are carotenoids packed as monolayers at the interfaces (between the dense lipide and less dense protein layers) within the rhabdomeres as in the retinal rods and chloroplasts (12-15), then from the average length, diameter, and the number of layers, the concentration of pigment molecules per layer or per rhabdomere can be calculated. The calculated value for the number of pigment molecules is $\sim 1 \times 10^9$ for a single rhabdomere. This pigment concentration is similar in order of magnitude to that experimentally determined for the retinal rod and chloroplast in a variety of animal and plant photoreceptors (4, 11, 12, 14, 15).

Investigations on the electric potential of the compound eye exposed to polarized light indicate that neither the whole eye nor a single ommatidium acts as the analyzer (1). The rhabdomere, as we have described it, is the only structural unit found in the compound eye which has a parallel rather than a radial symmetry in cross section. The radial arrangement in the ommatidium of such radially unsymmetrical units (rhabdomeres) suggests very strongly a relationship to the analysis of polarized light in the insect eye.

SUMMARY

The eyes of three eye mutants of *Drosophila melanogaster* were fixed and thin sections studied for its structural detail in the electron microscope. Each ommatidium was found to have seven retinula cells with an equal number of rhabdomeres (visual units). The rhabdomeres average 1.2μ in diameter and 60μ in length. Each rhabdomere consists of osmium-fixed dense bands averaging 120 A in thickness, and with less dense interspaces 200 to 400 A. There is an average of 23 dense bands or 46 interfaces per micron within the rhabdomere. The rhabdomere as we have presented it is a single structure of packed rods or tubes. The "fine structure" within the rhabdomere is similar to that observed by electron microscopy for the retinula of the house fly, and to the retinal rods of the vertebrate eye, and to the chloroplasts of plant cells in a variety of animal and plant photoreceptor structures. In addition, the radial arrangements within the ommatidium of radially unsymmetrical units, the rhabdomeres, is probably related to the analysis of polarized light in the insect eye.

BIBLIOGRAPHY

1. Autrum, H., and Stumpf, H., Das bienenaugen als analytor für polarisiertes licht, *Z. Naturforsch.*, 1950, **5b**, 116.
2. De Robertis, E., Electron microscope observations on the submicroscopic organization of the retinal rods, *J. Biophysic. and Biochem. Cytology*, 1956, **2**, 319.
3. Fernández-Morán, H., Fine structure of the insect retinula as revealed by electron microscopy, *Nature*, 1956, **177**, 742.
4. Hubbard, R., The molecular weight of rhodopsin and the nature of the rhodopsin digitonin complex, *J. Gen. Physiol.*, 1954, **37**, 381.
5. Krafka, J., Development of the compound eye of *Drosophila melanogaster* and its bar-eyed mutant, *Biol. Bull.*, 1924, **47**, 143.
6. Richards, M. H., and Furrow, E. Y., The eye and optic tract in normal and "eyeless" *Drosophila*, *Biol. Bull.*, 1925, **48**, 243.
7. Sjöstrand, F., The ultrastructure of the outer segments of rods and cones of the eye as revealed by the electron microscope, *J. Cell. and Comp. Physiol.*, 1953, **42**, 15.
8. Spassky, B., Cream of Wheat-molasses fly medium, *Drosophila Information Service*, Cold Spring Harbor, Long Island, New York, Carnegie Institution of Washington, 1943, **17**, 67.
9. Stephens, G. C., Fingerman, M., and Brown, F. A., The orientation of *Drosophila* to plane polarized light, *Ann. Entomol. Soc. Am.*, 1953, **46**, 75.
10. Von Frisch, K., Bees: Their Vision, Chemical Senses, and Language, New York, Cornell University Press, 1950.
11. Wolken, J. J., Molecular morphology of *Euglena gracilis* var. *bacillaris*, *J. Protozool.*, 1956, **3**, 211.
12. Wolken, J. J., Photoreceptor structures. I. Pigment monolayers and molecular weight, *J. Cell. and Comp. Physiol.*, 1956, **48**, 349.

13. Wolken, J. J., A comparative study of photoreceptors, *Tr. New York Acad. Sc.*, 1957, **19**, 315.
14. Wolken, J. J., Mellon, A. D., and Contis, G., Photoreceptor structures. II. *Drosophila melanogaster*, *J. Exp. Zool.*, 1957, **134**, No. 2.
15. Wolken, J. J., and Schwertz, F. A., Chlorophyll monolayers in chloroplasts, *J. Gen. Physiol.*, 1953, **37**, 111.

EXPLANATION OF PLATES

PLATE 134

FIG. 1. Cross-section very near the bases of two adjacent ommatidia showing the radially arranged rhabdomeres (R) attached to their respective retinula cells (rc). The one retinula cell contains a large nucleus (n) characteristic of sections near the base of the ommatidia. $\times 10,500$.

FIG. 2. Cross-section near the base of an ommatidium at higher magnification showing the lamellar structure in each rhabdomere and a finely differentiated line of attachment between the rhabdomere and the retinula cell R_1 to R_7 . $\times 22,500$.

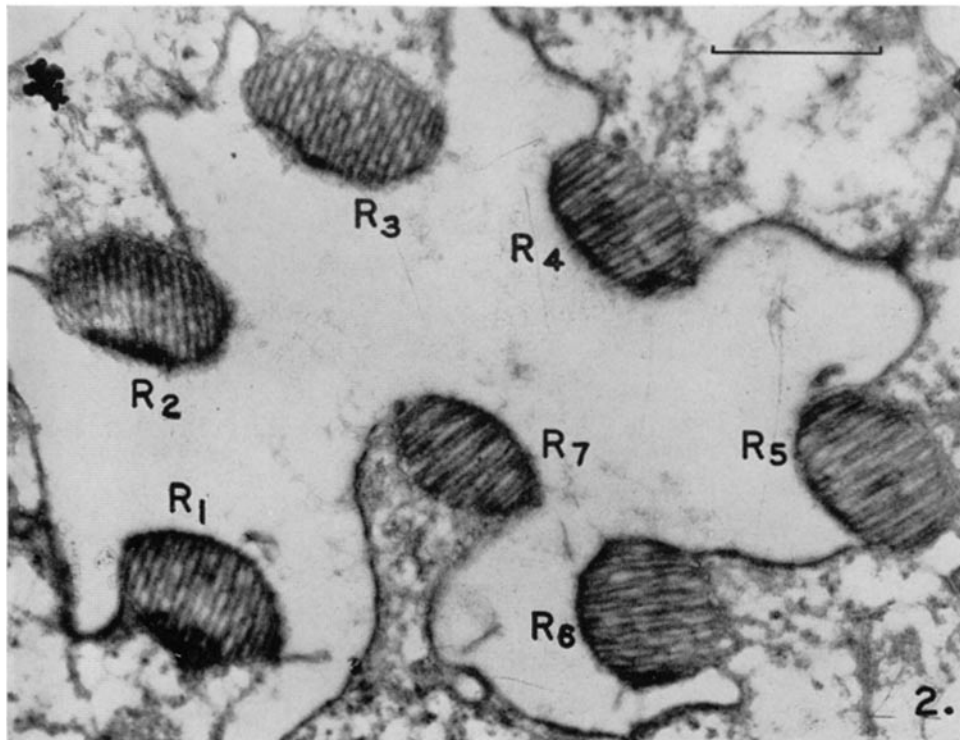
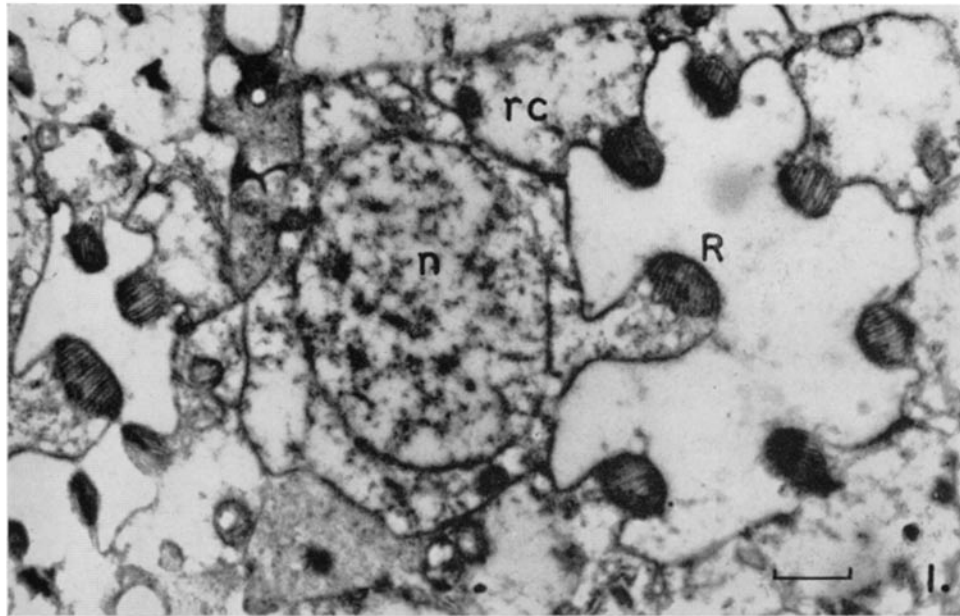

(Wolken *et al.*: Photoreceptor structures. III)

PLATE 135

FIG. 3. Oblique cross-section through the mid-portion of an ommatidium showing two different fine structural patterns in the rhabdomeres. Two of the rhabdomeres have a lamellar structure while the other five are hexagonal. $\times 6,400$.

FIG. 4. A single rhabdomere from Fig. 3 at higher magnification showing the closely packed hexagonal structure. No limiting membrane can be seen around the rhabdomere. $\times 24,000$.

FIG. 5. A single rhabdomere from Fig. 3 at higher magnification showing the lamellar pattern and distinctly scalloped border. $\times 24,000$.

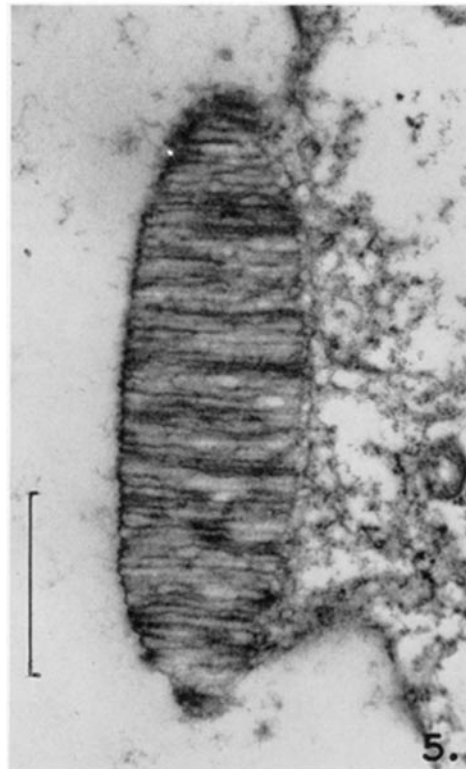
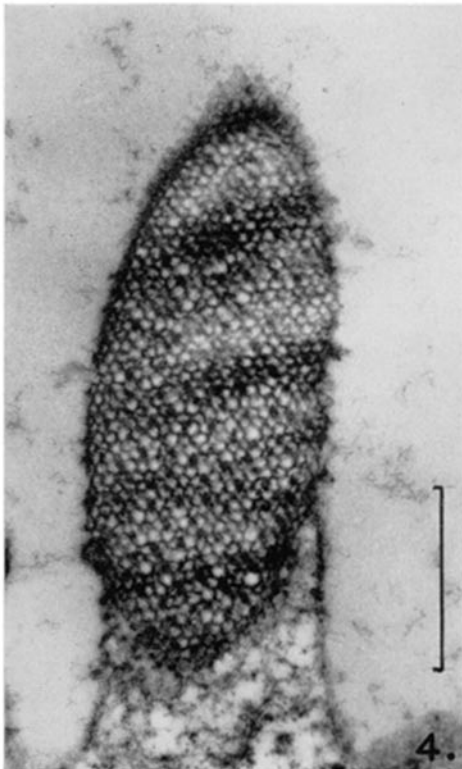

(Wolken *et al.*: Photoreceptor structures. III)

PLATE 136

FIG. 6. A longitudinal section at the distal end of the ommatidium showing three adjacent rhabdomeres and their fine structure. R_3 , a lamellar pattern; R_2 , the reticular pattern; and R_1 a lamellar-reticular pattern with the laminations being of the same order of magnitude as in R_3 . $\times 24,500$.

- a.* higher magnification of an area in R_2 . $\times 45,000$.
- b.* higher magnification of an area in R_3 . $\times 45,000$.

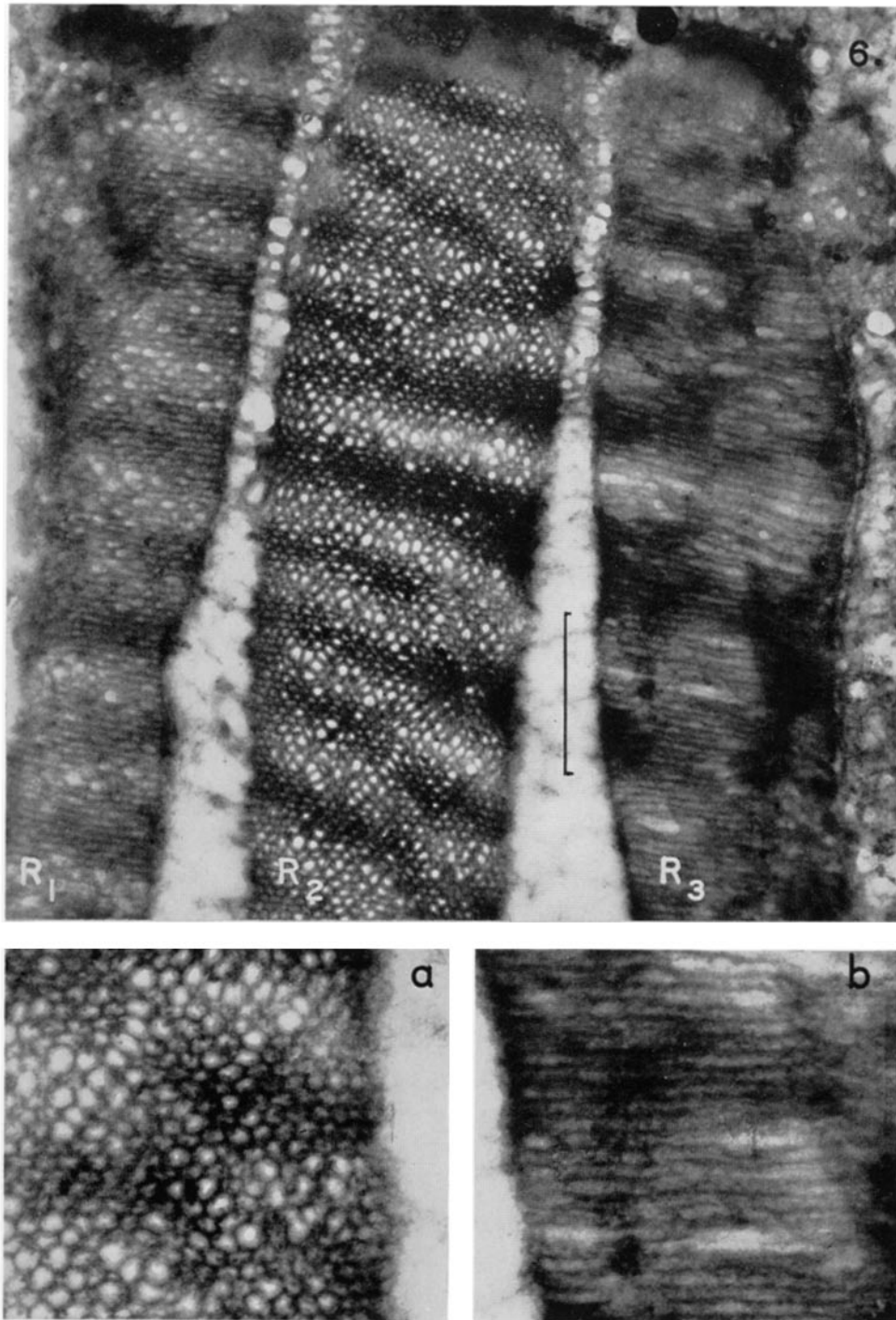

(Wolken *et al.*: Photoreceptor structures. III)

PLATE 137

FIG. 7. A longitudinal section of two adjacent rhabdomeres showing the reticular structure in R_2 and the lamellar-reticular structure in R_3 . $\times 29,000$.

FIG. 8. An extremely oblique section showing six rhabdomeres from the same ommatidium. The four centrally located rhabdomeres have a reticular appearance while the long rhabdomeres on either side of the figure are lamellar. $\times 6,550$.

FIG. 9. A higher magnification of a segment of a longitudinally cut rhabdomere which shows a lamellar-reticular structure. The interspaces are very elongated and the cross-walls are relatively indistinct. $\times 41,000$.

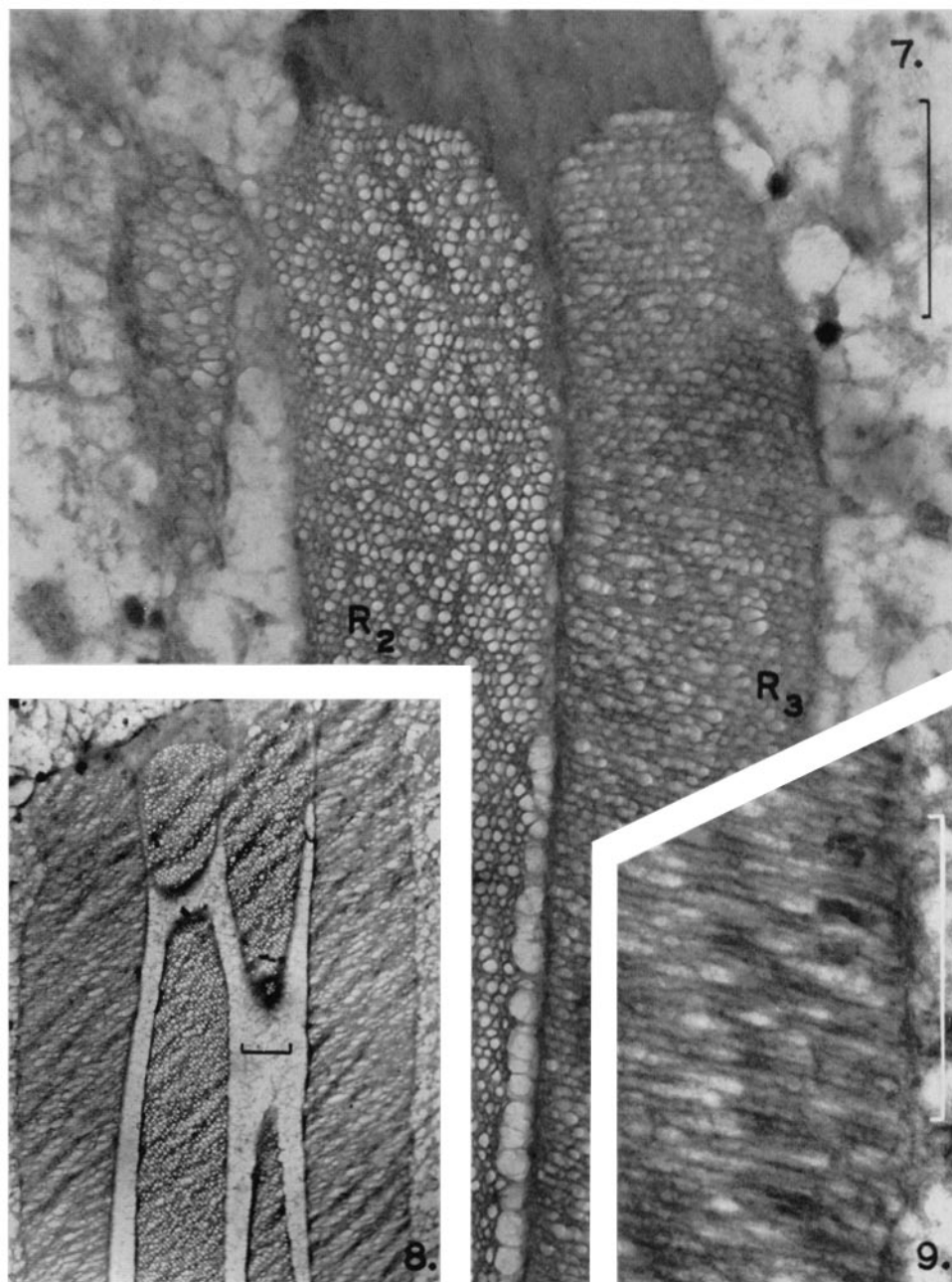

(Wolken *et al.*: Photoreceptor structures. III)

PLATE 138

FIG. 10 (*a*). Photomicrograph of a longitudinal section ($5\ \mu$ in thickness) through several ommatidia showing the lens, cone area, rhabdomeres, and pigment sheath, which corresponds to the diagrammatic section of an ommatidium (Text-fig. 1 *d*). $\times 1420$.

FIG. 10 (*b*). Diagram from Text-fig. 1 *b*, section *Y—Y* through ommatidia, to illustrate orientation of rhabdomeres within the ommatidia.

FIG. 10 (*c*). A cross-section of one of the rhabdomeres as would be oriented in section *Y—Y*, Text-fig. 1 *b*. $\times 46,700$.

FIG. 10 (*d*). A reconstructed section from electron micrographs through a rhabdomere to indicate a three-dimensional structure (surfaces 1, 2, and 3), as diagramed in Text-fig. 1 *d*. $\times 61,000$.

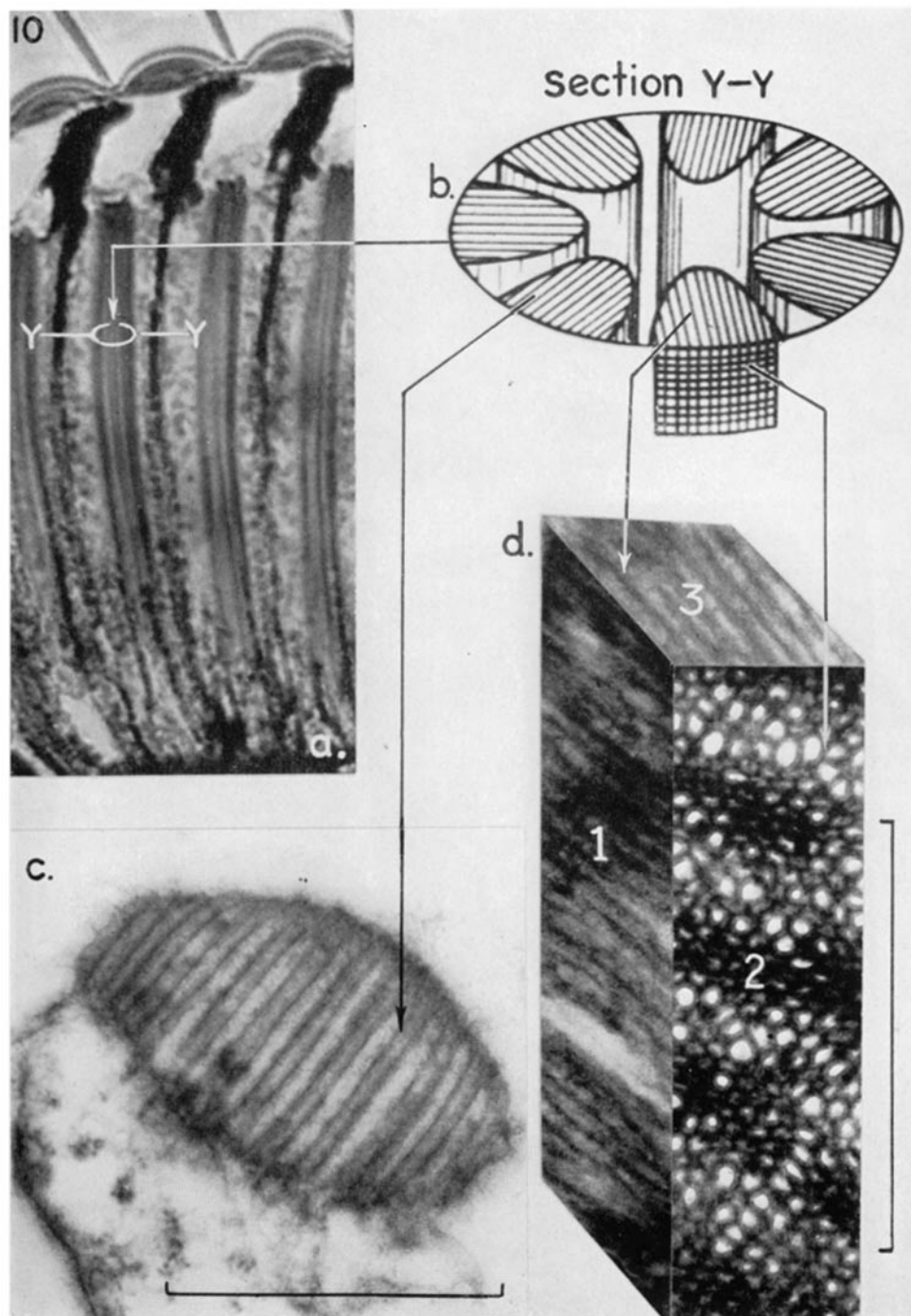

(Wolken *et al.*: Photoreceptor structures. III)