

Agrin Isoforms with Distinct Amino Termini: Differential Expression, Localization, and Function

Robert W. Burgess,* William C. Skarnes,[‡] and Joshua R. Sanes*

*Department of Anatomy and Neurobiology, Washington University Medical School, St. Louis, Missouri 63110; and

[‡]Department of Molecular and Cellular Biology, University of California, Berkeley, California 94720

Abstract. The proteoglycan agrin is required for postsynaptic differentiation at the skeletal neuromuscular junction, but is also associated with basal laminae in numerous other tissues, and with the surfaces of some neurons. Little is known about its roles at sites other than the neuromuscular junction, or about how its expression and subcellular localization are regulated in any tissue. Here we demonstrate that the murine agrin gene generates two proteins with different NH₂ termini, and present evidence that these isoforms differ in subcellular localization, tissue distribution, and function. The two isoforms share ~1,900 amino acids (aa) of common sequence following unique NH₂ termini of 49 or 150 aa; we therefore call them short NH₂-terminal (SN) and long NH₂-terminal (LN) isoforms. In the mouse genome, LN-specific exons are upstream of an SN-specific exon, which is in turn upstream of common exons. LN-agrin is expressed in both neural and non-neural tissues. In spinal cord it is expressed in discrete subsets of cells, including motoneurons. In contrast, SN-agrin is selectively expressed in the nervous system but

is widely distributed in many neuronal cell types. Both isoforms are externalized from cells but LN-agrin assembles into basal laminae whereas SN-agrin remains cell associated. Differential expression of the two isoforms appears to be transcriptionally regulated, whereas the unique SN and LN sequences direct their distinct subcellular localizations. Insertion of a “gene trap” construct into the mouse genome between the LN and SN exons abolished expression of LN-agrin with no detectable effect on expression levels of SN-agrin or on SN-agrin bioactivity in vitro. Agrin protein was absent from all basal laminae in mice lacking LN-agrin transcripts. The formation of the neuromuscular junctions was as drastically impaired in these mutants as in mice lacking all forms of agrin. Thus, basal lamina-associated LN-agrin is required for neuromuscular synaptogenesis, whereas cell-associated SN-agrin may play distinct roles in the central nervous system.

Key words: basal lamina • gene trap • motoneuron • neuromuscular junction • proteoglycan

Introduction

Agrin is a heparan sulfate proteoglycan that was purified from basal lamina (BL)¹ based upon its ability to induce clustering of acetylcholine receptors on cultured myotubes (McMahan, 1990). It has since been shown to be a critical motoneuron-derived organizer of synaptic differentiation at the neuromuscular junction in vivo (Gautam et al., 1996; Cohen et al., 1997a; Meier et al., 1997; Burgess et al., 1999). However, its broad expression pattern suggests that

it may play additional roles. For example, agrin is synthesized by many neuronal types in addition to motoneurons, as well as by some glial cells (Hoch et al., 1993; O'Connor et al., 1994; Ma et al., 1995; Stone and Nikolics, 1995; Cohen et al., 1997b). In neurons, it has been localized to both synapses and neurites (Escher et al., 1996; Mann and Kroger, 1996; Halfter et al., 1997; Koulen et al., 1999) and has been shown to affect synthesis and phosphorylation of transcriptional regulators when applied to cultured neurons (Ji et al., 1998; Hilgenberg et al., 1999). In addition, agrin is present in distinct subsets of BLs in numerous nonneural tissues. In kidney, it is a major proteoglycan of the glomerular BL (Groffen et al., 1998b). In view of evidence that heparan sulfate proteoglycans are critical determinants of renal permeability (Kanwar et al., 1991), agrin has been suggested to be an essential part of the glomerular filter (Raats et al., 2000). Likewise, agrin is

Address correspondence to Joshua R. Sanes, Department of Anatomy and Neurobiology, Washington University Medical School, 660 S. Euclid Ave., Box 8108, St. Louis, MO 63110. Tel.: 314-362-2507. Fax: 314-747-1150. E-mail: sanesj@pcg.wustl.edu

¹Abbreviations used in this paper: AChR, acetylcholine receptors; bp, base pair; BL, basal lamina; E, embryonic day; ES, embryonic stem cells; EF1 α , elongation factor 1 α ; lacZ, *Escherichia coli* β -galactosidase; LN, long NH₂ terminus; RACE, rapid amplification of cDNA ends; RT, reverse transcriptase; SN, short NH₂ terminus.

prominent in the BLs of the cerebral microvasculature, and its levels in this BL increase during the period that the blood–brain barrier acquires its mature properties. This pattern of expression has led to the speculation that agrin contributes to the integrity of this barrier (Barber and Lieth, 1997). Despite these intriguing data, little is known about roles of agrin at sites other than the neuromuscular junction, or about how its expression and subcellular localization are regulated in any tissue.

Clues to the mechanism of agrin's action at the neuromuscular junction have come from analysis of its multiple isoforms. Alternative splicing near the 3' end of the agrin gene generates isoforms that contain or lack short segments in the COOH-terminal third of the protein. Inclusion of a four amino acid (aa) insert at a site called A in chicks and Y in mammals is required for agrin to bind to heparin. Inclusion of 8, 11, or 19 (8 + 11) aa segments at a nearby site, called B in chicks and Z in mammals, is required for agrin to induce postsynaptic differentiation at the neuromuscular junction (Ferns et al., 1992; Ruegg et al., 1992; Gesemann et al., 1995, 1996; Campanelli et al., 1996; O'Toole et al., 1996; Burgess et al., 1999). Here we describe heterogeneity in the 5' end of the agrin gene that contributes to the diversity of agrin's localization, tissue distribution, and function. We show that mice express two isoforms of agrin in which distinct NH₂-terminal peptides of 49 or 150 aa precede ~1,900 aa of common sequence. We refer to the isoforms as short NH₂-terminal (SN) and long NH₂-terminal (LN), respectively. The existence of these distinct isoforms explains the previously noted lack of homology between the NH₂ termini of agrins isolated from rats and chicks (Rupp et al., 1991; Tsim et al., 1992; Denzer et al., 1995). SN- and LN-agrins are likely to be transcribed from distinct promoters, and they are expressed in different patterns throughout development. SN-agrin is largely confined to the nervous system, whereas LN-agrin is broadly distributed in neural and nonneural tissues. Moreover, analyses of native and recombinant protein indicate that SN- and LN-agrin exhibit distinct subcellular localizations, determined by their NH₂ termini: LN-agrin associates with BLs (and all BL-associated agrin is LN-agrin), whereas SN-agrin remains attached to cell surfaces. Finally we use mutant mice in which expression of only LN-agrin is abolished to show that this isoform is essential for synapse formation at the neuromuscular junction. Thus, analyses of gene expression, protein localization, and mutant phenotype all support the idea LN-agrin is a component of BLs and critical for signaling at the neuromuscular junction, whereas SN-agrin may play distinct roles in neuron–neuron interactions.

Materials and Methods

Analysis of cDNA and Genomic Clones

To identify cDNAs encoding 5' ends of agrin, we performed anchored PCR from an embryonic day (E) 18 mouse library (CLONTECH Laboratories, Inc.). A primer in exon 1 of agrin (according to the numbering scheme of Rupp et al., 1992) and a second primer in the vector were used for amplification. Reaction products were separated on agarose gels, blotted to filters, and hybridized with ³²P-labeled agrin-specific oligonucleotides. A fragment identified in this way was sequenced, and found to encode SN-specific–translated and 5'-untranslated sequences. Its sequence is available from EMBL/Genbank/DDBJ (accession number AF294811).

LN-agrin was identified by a search of public databases; an EST (accession number AA024084) was obtained and resequenced. Bacterial artificial chromosomes containing the 5' end of the agrin gene were identified by PCR screening of gridded clones from a commercial library (Genome Systems). Two positive clones were mapped by restriction digestion and Southern blotting. Sequencing to determine the intron–exon boundaries was performed directly from the bacterial artificial chromosomes DNA using 5 μg of DNA per reaction.

Expression of Recombinant Agrin

CHO cells were grown on glass coverslips coated with laminin (GIBCO BRL; 20 μg/ml). The cells were transfected with cDNAs encoding either full-length rat agrin (Campanelli et al., 1991) or with a construct expressing the first 83 aa of rat SN-agrin fused to a COOH-terminal FLAG tag. This construct was generated by PCR and contained the same 5' UTR and the first 249 base pair (bp) of coding sequence as the full-length rat agrin. At the 3' end, an MfeI site was added and the PCR product was ligated into an expression vector upstream of a FLAG tag. An LN-agrin expression construct was made in the same vector; it began with the first 15 aa of the chick sequence, followed by mouse LN-agrin sequence.

After transfection, living cells were stained at 37°C for 30 min using either a polyclonal anti-agrin antibody generated against the COOH-terminal 50 kD of human agrin (a gift of David Glass, Regeneron Pharmaceuticals, Tarrytown, NY), or with anti-FLAG monoclonal antibody M2 (Sigma-Aldrich). The cells were then washed briefly, fixed in 4% paraformaldehyde, and incubated with fluorescein-conjugated anti-mouse or Alexa 488-conjugated anti-rabbit secondary antibodies.

Transcript Analysis

RNA was isolated for reverse transcriptase (RT)-PCR by homogenization in guanidinium isothiocyanate and phenol extraction. For reverse transcription, 10 μg of total RNA was incubated with Avian Myeloblastosis Virus RT and a mixture of random hexamers and oligo-dT. For PCR, aliquots of the resulting cDNA were amplified 40 rounds using primers indicated in the figures. For Northern blotting, mRNA was isolated by passage over an oligo-dT cellulose column. Denaturing gels were run and blotted onto nylon membrane. In most cases, 5 μg of poly A⁺ mRNA was loaded per lane. Probes were generated using ³²P incorporation by random priming of PCR products specific for each transcript. Hybridization was carried out at 50°C in 50% formamide buffer, and the final wash was 0.2× SSC, 0.1% SDS at 65°C. Equivalent loading of lanes was assessed by stripping blots and reprobing them with elongation factor 1α (EF1α).

Gene Trapping

A mutation in the agrin locus was generated by the insertion of a β-gal gene (neomycin phosphotransferase fused to *Escherichia coli* β-galactosidase [lacZ]) between the LN and SN exons. This insertion was identified from an insertional mutagenesis screen in embryonic stem (ES) cells that had been designed to identify mutations in genes encoding secreted and transmembrane proteins (Skarnes et al., 1995). Individual clones from this screen were analyzed by 5' RACE (rapid amplification of cDNA ends) to identify the intercepted transcripts (Townley et al., 1997). ES cells were injected into mouse blastocysts to generate germ line chimeras.

Histology

For lacZ staining, tissues were fixed in 4% paraformaldehyde, with or without 0.25% glutaraldehyde, at room temperature. Tissue was then equilibrated with 15% and 30% sucrose in PBS, frozen, and sectioned in a cryostat at 10–20 μm. Slides were stained at 30°C for 6–18 h as described by Sanes et al. (1986) and then mounted in 80% glycerol for viewing.

Tissue sections or whole muscles were prepared for immunohistochemistry as described in Burgess et al. (1999). Agrin staining was done using a rabbit polyclonal antibody against the COOH-terminal 50 kD of human agrin. Nerves were visualized with anti-NF200 (Sigma and Sternberger Monoclonals) and anti-SV2 (Buckley and Kelly, 1985) or anti-synaptophysin (Zymed Laboratories). AChRs were stained with rhodamine α-bungarotoxin (Molecular Probes).

For in situ hybridization, tissue was fixed overnight in 4% paraformaldehyde, equilibrated with 15% and 30% sucrose, frozen and sectioned as above. The tissue was allowed to air dry for up to 2 h and then hybridized immediately. Hybridization was done using a solution of ~250 ng/ml digoxigenin-labeled riboprobes in a 50% formamide buffer at 65°C over-

night and washed and developed according to Schaeren-Wiemers and Gerfin-Moser (1993). The SN probe included the entire unique 5' untranslated (466 nucleotides) and unique coding sequence to the *HinfI* site.

Clustering Activity Assay

Brains and spinal cords from E18 mice were homogenized and used to induce AChR clustering on myotubes as described in Sanes et al. (1984). In brief, tissue was dissected from the animals, homogenized in ground glass homogenizers at 25% wt/vol in DME with 10% horse serum. The homogenate was then spun at 4°C in a microfuge for several hours and the supernatant was sterilized by passage through a 0.2-µm syringe filter. The supernatant was diluted and applied to myotubes that had been cultured from neonatal mice as described by Gautam et al. (1996). After 18 h of treatment, the myotubes were fixed in 2% paraformaldehyde, rinsed in PBS, and stained with rhodamine α-bungarotoxin for 2 h. The coverslips were then mounted and the number of AChR clusters was counted.

Results

Isolation of Chicklike and Ratlike Agrin Isoforms

cDNAs encoding agrin have been isolated from rat, Torpedo, chicken, human, and mouse (Rupp et al., 1991, 1992, Ruegg et al., 1992; Smith et al., 1992; Denzer et al., 1995; Groffen et al., 1998a). The deduced primary sequence is highly conserved among all of these species with one notable exception: the NH₂-terminal 50 residues of rat agrin (Rupp et al., 1991) are unrelated to sequences in other agrins or to any other sequences in public databases. In contrast, NH₂ termini of reported human and mouse agrins are homologous to the sequence initially isolated from chick (Torpedo sequence did not extend to the NH₂ terminus). Although this difference might reflect authentic interspecific differences, we considered an alternative possibility, that multiple agrin mRNAs with different 5' ends exist in a single species (Fig. 1 A). Because our previous studies of agrin function have been performed in mice (Gautam et al., 1996, 1999; Burgess et al., 1999), we began the present study by seeking an isoform of mouse agrin with a ratlike NH₂ terminus.

A cDNA encoding the NH₂ terminus of agrin was cloned by anchored PCR from an embryonic mouse cDNA library (see Materials and Methods). This 700-bp

PCR product contained 466 bp of 5'-untranslated sequence (5' UTR) followed by 148 bp of coding sequence homologous to rat but not chick agrin, and then 73 bp of sequence homologous to both chick and rat agrin (Fig. 1 B). The 5' UTR contained stop codons upstream of the proposed start ATG, confirming the NH₂ terminus of the agrin open reading frame. This mouse NH₂ terminus, like the rat sequence, lacks a canonical signal peptide. If the NH₂ terminus were to function as a leader sequence, its most likely cleavage site based on the parameters of von Heijne (1986), is predicted to after residue 52, 3 aa into the common sequence.

We also confirmed the existence of murine cDNAs that encode a chicklike NH₂ terminus. In a search of public databases, several ESTs corresponding to the NH₂ terminus of agrin were identified and one was obtained and sequenced. The 5' end of this cDNA encoded a peptide that was highly homologous to aa 16–211 of chick agrin but was dissimilar to rat agrin before aa 150 (Fig. 1 B). In chick, alternative splicing leads to the inclusion or exclusion of a 7 aa stretch at approximately aa 150 (Denzer et al., 1995; Tsen et al., 1995). All of the ESTs we identified lacked this 7 aa stretch, and attempts to identify it by PCR and RT-PCR gave negative results (data not shown). Therefore, this exon may not be present in mice.

These results, and others presented below, demonstrate that the agrin gene encodes two classes of patterns, in which unique sequences of 49 or 150 aa precede ~1,900 aa of common sequences.

Distinct Subcellular Localizations of LN- and SN-Agrin

Denzer et al. (1995, 1997) reported that recombinant chick agrin (LN-type) is secreted from transfected COS cells and binds to laminin in the extracellular matrix. In contrast, Campanelli et al. (1991) found that recombinant rat agrin (SN-type) is externalized by transfected CHO cells, but remains associated with the cell surface. Although these studies used different methods and analyzed agrin from different species, their results suggested that the localization of agrin is affected by its NH₂ terminus. To test

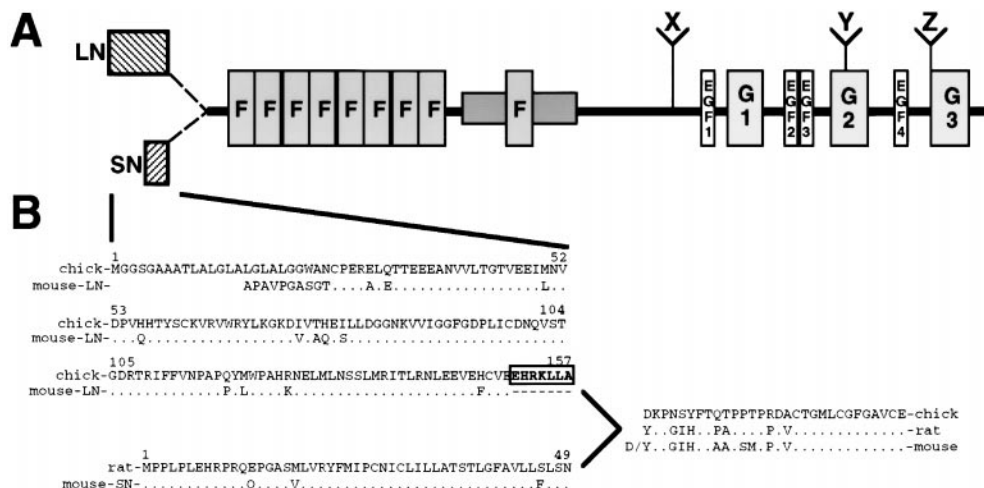

Figure 1. Distinct NH₂ termini of agrin. (A) Schematic of agrin protein structure, showing its major domains (laminin G domains, EGF repeats, and follistatin [F] repeats), sites of alternative splicing (X, Y, Z) and alternate NH₂-terminal extensions (SN and LN). (B) The two alternative NH₂ termini of mouse agrin, aligned with prototype LN and SN sequences from chick and rat, respectively. Dots indicate identity. The boxed heptapeptide in the chick sequence represents an alternatively spliced exon; a homologous segment has not yet been identified in murine LN-agrin.

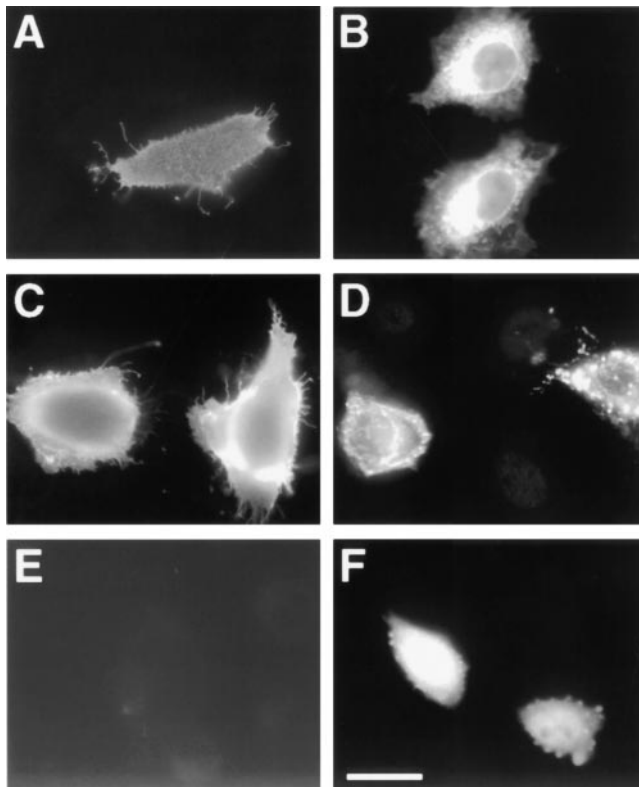

Figure 2. The NH₂ terminus of SN-agrin mediates its association with cells. CHO cells were transfected with vectors encoding the NH₂ terminus of SN-agrin fused to FLAG (A and B), full-length SN-agrin (C and D), or the NH₂ terminus of LN-agrin fused to FLAG (E and F). Cells were stained with anti-FLAG (A, B, E, and F) or anti-agrin (C and D), either live to detect cell surface proteins (A, C, and E) or after fixation and permeabilization (B, D, and F). SN-agrin reached the cell surface, but no staining of live cells was detectable with the LN-FLAG construct. Staining of fixed and permeabilized cells indicated expression levels were similar for each construct. Bar, 20 μm.

this idea, we generated expression vectors in which the NH₂ termini of mouse LN- and SN-agrins were fused to the FLAG epitope tag. The SN-FLAG vector encoded the 49 aa of SN-specific sequence plus 34 aa of common sequences, whereas the LN-FLAG vector encoded 150 aa of LN-specific sequences plus the same 34 aa of common sequence. These vectors were transfected into CHO cells, which had been plated on dishes coated with laminin. Two days later, the cultures were stained either live or after fixation and permeabilization.

As shown in Fig. 2 A, the SN-FLAG fusion protein was efficiently externalized, and remained associated with the surface of transfected CHO cells. Staining extended to the tips of cellular processes. We did not observe any staining of presumably untransfected cells in the vicinity of SN-FLAG-rich (transfected) cells, suggesting that the fusion protein remained associated with the membrane after externalization, rather than being secreted and then retrieved from the medium. In all of these respects, the disposition of SN-FLAG was indistinguishable from that of full-length rat agrin (Fig. 2, C and D; and Campanelli et al., 1991). In contrast, cells transfected with the LN-FLAG vector were intensely stained after permeabiliza-

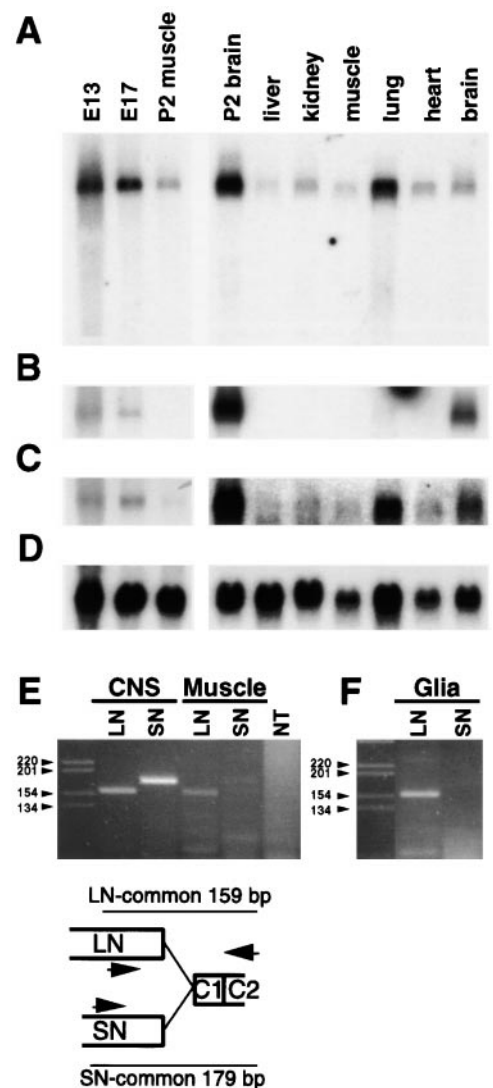

Figure 3. Tissue distribution of LN- and SN-agrin. (A–D) Northern analysis. Blots were hybridized sequentially with probes specific for LN-agrin (A), SN-agrin (B), all agrin isoforms (C), and the ubiquitously expressed RNA, EF1α (D). In adults, LN-agrin RNA is broadly distributed whereas SN-agrin is selectively expressed in brain. Both forms are present at E13 and E17 (RNA was from whole embryos). The sum of SN- and LN-agrins appear to account for the common signal. (E) Analysis of E18 CNS and muscle RNA by RT-PCR indicated that LN is present in both tissues, whereas SN was below the level of detection in muscle. NT, PCR performed with a mixture of LN and SN primers but no template. The PCR strategy and predicted sizes of products are shown in the sketch. (F) Analysis of cortical glial cultures by RT-PCR indicates that LN is expressed by glia, whereas SN is not. The strategy is the same as that in E.

tion, but not detectably stained when incubated with anti-FLAG before fixation (Fig. 2, E and F).

Selective Expression of SN-Agrin in Nervous System

We used Northern blotting to compare expression patterns of SN- and LN-agrin mRNAs. Blots were probed sequentially with four probes: one comprising LN-specific sequences (Fig. 3 A), a second comprising SN-specific se-

quences (Fig. 3 B), a third comprising common sequences (Fig. 3 C), and a fourth that recognized products of the ubiquitously expressed gene, EF1 α (Fig. 3 D). SN-specific, LN-specific, and common probes all hybridized to a band of 8.2 kb. In adults, LN-agrin RNA was present in all tissues tested, whereas SN-agrin was selectively expressed in brain. (A long exposure of the SN Northern blot revealed low levels of expression in lung; data not shown.) Both LN- and SN-agrin were expressed in embryos, at levels that declined with age. Likewise, SN- and LN-agrin RNAs were more abundant in P2 brain than in adult brain, and LN-agrin RNA was more abundant in P2 muscle than in adult muscle. In all tissues tested, RNAs detected with the common probes appeared to represent the sum of LN- and SN-specific signals, supporting the idea that LN and SN transcripts together account for all agrin transcripts.

To date, agrin has been most intensively studied in the central nervous system and in muscle. To further examine the expression of SN and LN isoforms in these two tissues, we used RT-PCR. As shown in Fig. 3 E, a reverse primer in the second common exon was paired with either an SN- or a LN-specific primer. SN-agrin RNA was readily detected in E18 central nervous system (brain and spinal cord), but was barely detectable in E18 muscle. In contrast, LN-agrin RNA was detectable in both tissues. These results confirm that both LN- and SN-unique sequences are continuous with common sequence, and support the conclusion from Northern blotting that SN-agrin is selectively expressed in nervous tissue.

Genomic Organization of the LN and SN Exons

Knowing that LN- and SN-agrin RNAs are differentially expressed, we asked how LN-specific, SN-specific, and common sequences are arranged in the agrin gene. To this

end, we isolated a >100-kb genomic clone that carried both SN- and LN-specific coding sequences. The clone was restriction mapped and partially sequenced to determine intron–exon boundaries. As shown in Fig. 4, LN-specific sequences are encoded by at least three exons, all of which lie within a 5-kb stretch. These exons are 8-kb upstream of a single exon that encodes the entire SN-specific coding sequence as well as the SN-specific 5' UTR. The SN exon, in turn, is separated from the first two common exons by introns of 0.4 and 4 kb.

Isolation of a LN-specific Gene Trap Insertion

Skarnes et al. (1995) performed a “gene-trap” screen in which the mutagenic cassette contained a splice acceptor site followed by a β -geo fusion protein. Inclusion of a transmembrane domain in the cassette led to selection for proteins with signal sequences. 5' RACE was then used to identify the transcripts that had been intercepted by the gene trap insertion (Townley et al., 1997). One RACE-derived sequence (Ex192) corresponded to the LN-specific NH₂ terminus of agrin, and ended precisely at the 3' end of the last LN exon (compare Figs. 4 B and 5 A). This sequence suggested that the vector had integrated into the intron that separated the LN exons from the SN exon. Southern blot analysis of genomic DNA confirmed this location (not shown). We generated chimeric mice from these ES cells by blastocyst injection and then bred the chimeras to generate heterozygous and eventually homozygous mutants. Heterozygotes were phenotypically normal, and homozygotes exhibited defects described below.

Expression of agrin isoforms was examined in the mutant animals by Northern blotting, using LN- and SN-specific probes. The LN-specific probe recognized a transcript

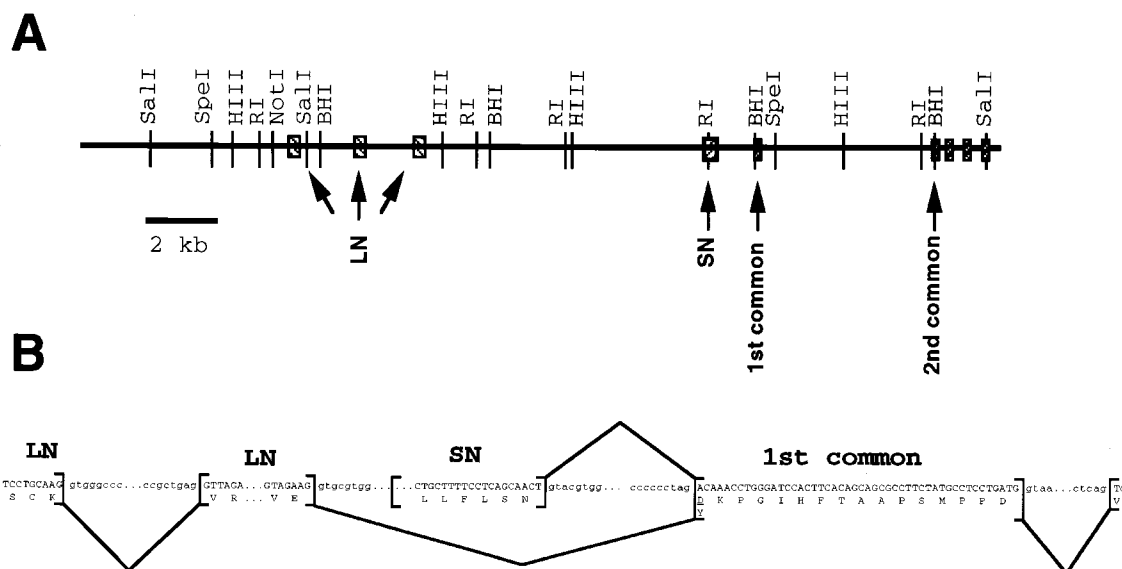

Figure 4. Location of SN, LN, and common exons in the mouse agrin gene. (A) Map of the 5' end of the agrin gene, as determined by restriction digestion, PCR, and Southern blotting. LN-specific sequences are encoded by at least three exons that lie 8-kb upstream of a single exon that encodes SN-specific sequences. The SN exon is separated by introns of 0.4 and 4 kb from first and second common exons. The second common exon corresponds to the first exon mapped by Rupp et al. (1992). (B) Predicted pattern of splicing to generate LN- and SN-agrin transcripts. The intron–exon boundaries all contain consensus splice donor (gt) and acceptor (ag) sequences and preserve the predicted agrin reading frame.

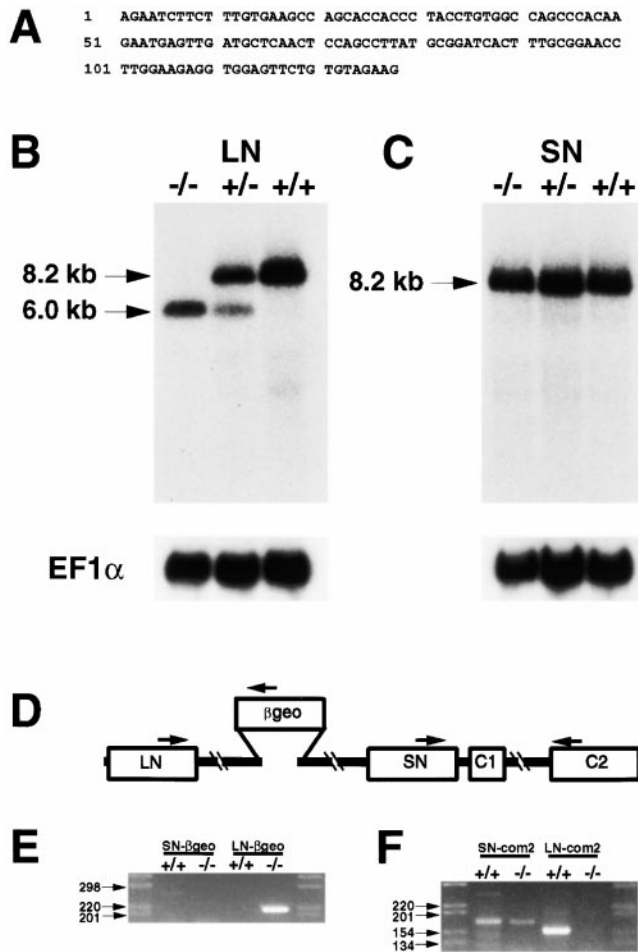

Figure 5. Characterization of a gene trap insertion that selectively intercepts LN-agrin transcripts. (A) Partial sequence of the transcript intercepted by the agrin^{LN} gene trap insertion was determined by 5' RACE. The sequence matches LN-agrin and terminates at the end of the LN-specific exon. (B and C) Northern analysis of poly A⁺ mRNA from the CNS of E18 agrin^{LN/LN}, agrin^{LN/+}, and agrin^{+/+} littermates, hybridized with LN- (B) and SN-specific (C) probes. The wild-type LN transcript is shifted from 8.2 to 6.0 kb by the β-geo insertion, whereas the size and abundance of the SN transcript are unaffected. Blots were standardized with EF1α. (D–F) RT-PCR analysis of RNA from CNS of mutants and controls, using strategy shown in D. Amplification from LN to β-geo yielded a band in mutants but not wild-type littermates, whereas primers in SN and β-geo gave no amplification product in either genotype (E). The wild-type transcript for SN-agrin was still present in mutant CNS, but the LN transcript is below the level of detection by RT-PCR (F).

of 8.2 kb in wild-type mice and a transcript of 6.0 kb in agrin^{LN/LN} mice (Fig. 5 B). The decrease in size reflects the replacement of ~7 kb of common agrin sequence by ~5 kb of β-geo sequence. As expected, both 6.0- and 8.2-kb LN-reactive RNAs were present in agrin^{LN/+} heterozygotes. In contrast, the SN-specific probe recognized RNAs of identical size and abundance in mice of all three genotypes (Fig. 5 C). Likewise, levels of SN-agrin were similarly low in nonneuronal tissues of both agrin^{LN/LN} and control animals (not shown), indicating that SN-agrin is not upregulated in the absence of LN.

The complete absence of 8.2-kb RNA from the mutant suggested that the insert intercepted most if not all LN transcripts. To assess the completeness of the disruption, we used the more sensitive method of RT-PCR, using primers diagrammed in Fig. 5 D. LN transcripts were intercepted by the β-geo construct and wild type LN transcripts were undetectable in homozygous mutant (Fig. 5, E and F). There was no evidence for splicing from the insert to the SN exons, consistent with the genomic analysis indicating that the insertion is upstream of the SN exon. Together, Southern, Northern, and RT-PCR analyses indicate that the gene trap insert has generated an effective null allele of LN-agrin, with no detectable effect on expression of SN-agrin.

Distinct Patterns of LN- and SN-Agrin Expression in Central Nervous System

In the agrin^{LN} allele, genomic regulatory elements that normally direct expression of LN-agrin would be expected to direct expression of a LN-β-geo fusion protein, which is detectable with the histochemical stain for lacZ. We therefore used lacZ histochemistry to assess the cellular distribution of LN-agrin in the central nervous system of phenotypically normal agrin^{LN/+} heterozygotes at E14 and E18. Weak signals were present in numerous areas, including cerebellum, cortex, and hippocampus, but four sites of expression were especially prominent at both ages. First, small blood vessels were intensely stained throughout the nervous system (Fig. 6, A and B). Second, neural progenitors were stained in the ventricular zones of the cerebral cortex (Fig. 6 B), hippocampus (Fig. 6 D), and spinal cord (Fig. 6 E). Third, sensory neurons were lacZ positive in dorsal root ganglia (Fig. 6 E) and in the trigeminal ganglion (not shown). Fourth, motoneurons were intensely stained, indicating that these cells express high levels of LN-agrin. Selective staining of motoneurons was apparent both in the spinal cord (Fig. 6 E) and in the hindbrain (Fig. 6 H). Staining was intense at both E14 and E18, and expression persisted into adulthood (Fig. 6 I). Selective expression of LN-agrin by motoneurons is noteworthy in view of functional studies reported below.

In parallel we used in situ hybridization to confirm the localization of LN-agrin (not shown) and to map expression of SN-agrin (Fig. 6, C and F). The pattern of SN-agrin expression was markedly different from that of LN-agrin. In forebrain, for example, levels of SN-agrin were highest in postmitotic neurons of the cortical plate, moderate in migrating neuroblasts of the intermediate zone, and lowest in progenitors of the ventricular zone. This pattern was the opposite of that seen for LN-agrin, which was expressed at highest levels in the ventricular zone and at lowest levels in the cortical plate (Fig. 6, B and C). In spinal cord, SN-agrin was broadly distributed, in contrast to the motoneuron-selective expression of LN-agrin (Fig. 6, E and F). SN-agrin RNA was also abundant in midbrain, hindbrain, retina, olfactory epithelium, trigeminal ganglion, and sympathetic ganglia (not shown).

The broad distribution of SN-agrin RNA in the CNS raised the possibility that this isoform was expressed by glial cells in addition to neurons. To test this possibility, we used isoform-specific primers to amplify agrin mRNAs

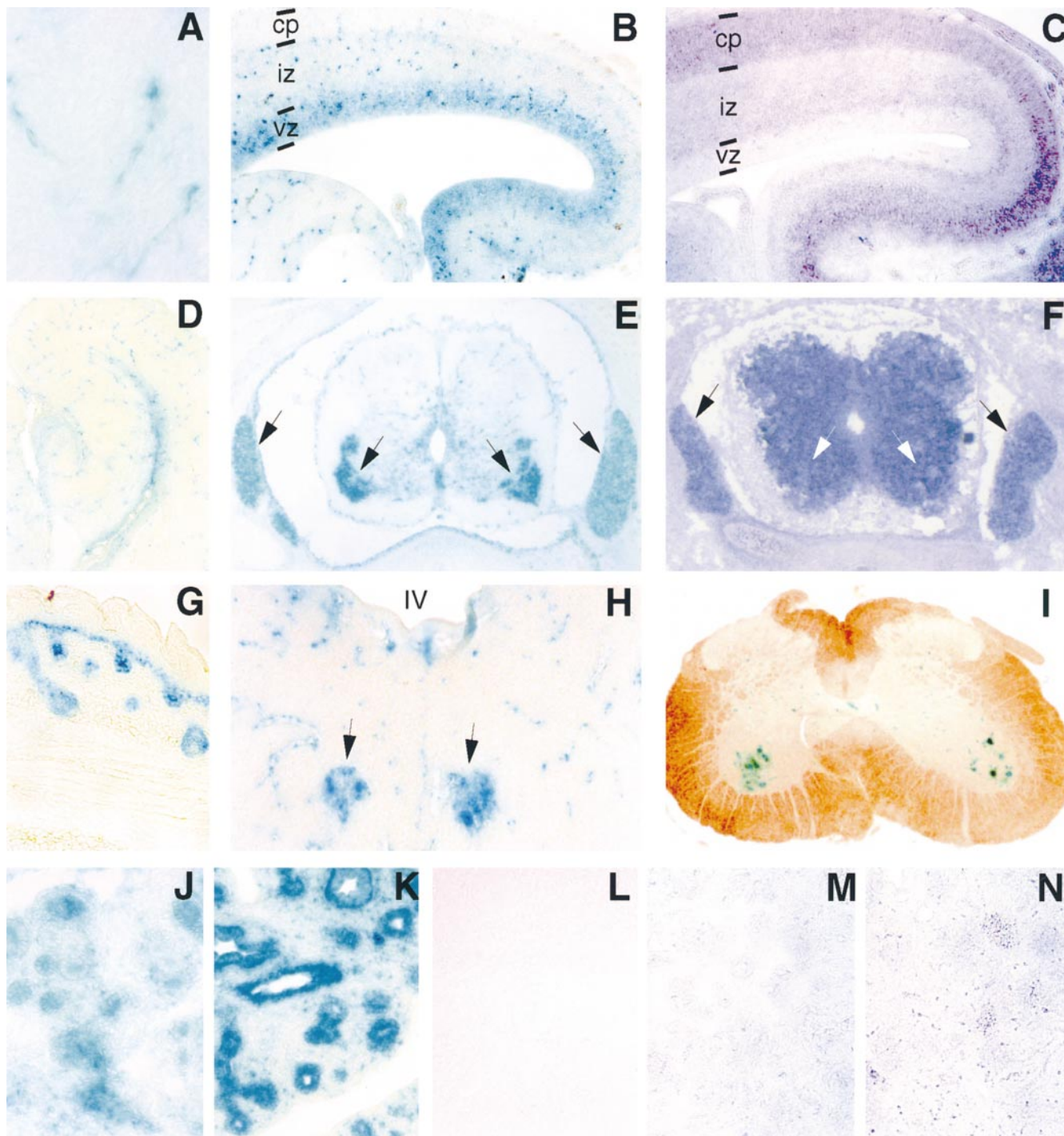

Figure 6. Expression of LN- and SN-agrin. The β -geo insertion allowed LN-agrin expression to be analyzed by lacZ staining in heterozygotes (A, B, D, E, and G–L), whereas SN-agrin RNA was detected by in situ hybridization (C, F, M, and N). (A and B) In the brains of E14 mice, LN-agrin is expressed in cerebral blood vessels and in the ventricular (vz) and intermediate zone (iz) of the cortex, but not in the cortical plate (cp; B). (C) SN-agrin is expressed in a pattern that is complementary to the LN pattern, being most abundant in the postmitotic cells of the cortical plate. (D) In E18 embryos, LN-agrin continues to have very restricted expression in the hippocampus, being present only near the ventricles and in blood vessels. (E) In the spinal cord, LN-agrin is strongly expressed by motoneurons and sensory neurons of the DRG (arrows). (F) SN-agrin is widely distributed in many neuronal cell types in both the DRG and the spinal cord, although motoneurons are not more intensely positive than other cell types (white arrows). (H) LN-agrin is also expressed by cranial nerve motor nuclei in the hindbrain (E18 horizontal section; IV, fourth ventricle; arrowheads, oculomotor nuclei). (I) Motoneuron expression of LN-agrin persists into adulthood. (G and J–N) Nonneuronal cells that abut basal laminae express LN-agrin but not SN-agrin. Epidermal cells in E18 skin (G), kidney glomeruli and tubules (J), and pulmonary epithelium (K) are all positive for LN-agrin. No lacZ activity was present in littermate controls in any tissue (E18 kidney shown, L). Consistent with northern blotting, SN-agrin is not expressed at levels detectable by in situ hybridization in nonneuronal tissues such as kidney (M) or lung (N).

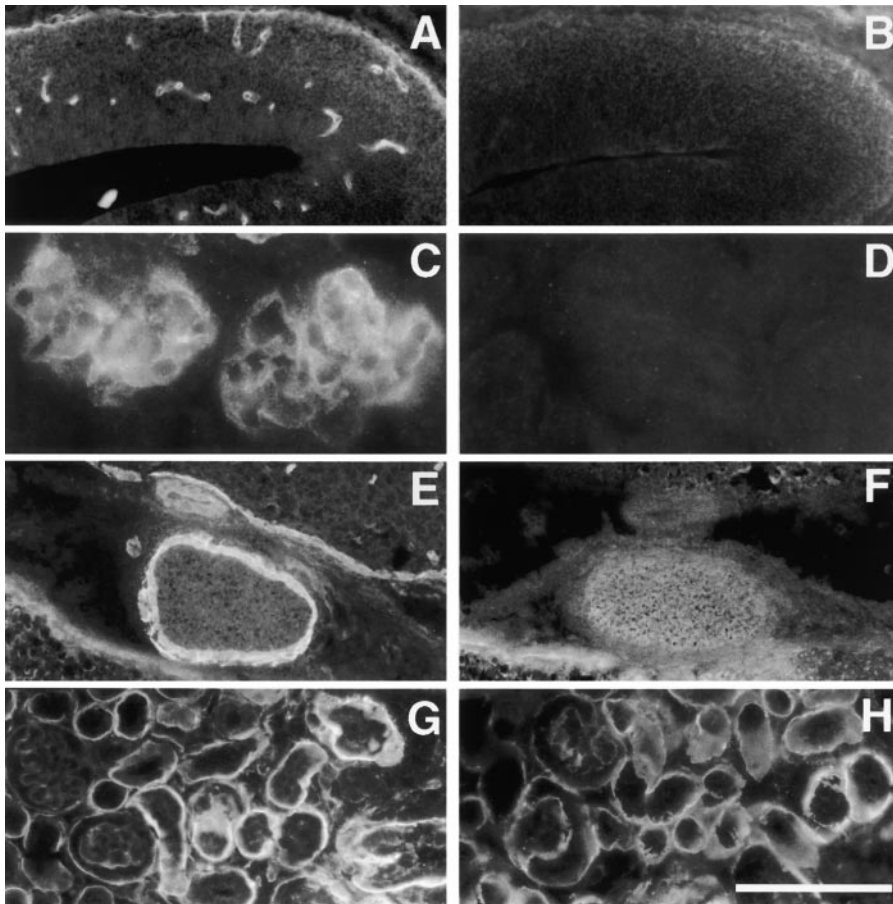

Figure 7. LN-agrin accounts for all agrin in BLs. Immunohistochemistry with an anti-agrin antibody shows that agrin is present in BLs of cerebral microvasculature (A), renal glomeruli (C), and pia and sheath of the optic nerve (E) at E18. No immunoreactivity is detectable at any of these sites in agrin^{LN/LN} mice (B, D, and F). Basal laminae remain intact as indicated by anti-laminin staining in wild-type (G) and agrin^{LN/LN} mutant (H) kidney. Bar: (A, B, E, and F) 250 μ m; (C and D) 50 μ m; and (G and H) 125 μ m.

from isolated, cultured cortical glia. LN-agrin was expressed by the glia (which include the astrocytes that contribute to the microvascular BL), but SN was not (Fig. 3 F). Thus SN-agrin may be selectively expressed not only in the nervous system, but by neurons.

BL-associated Agrin Is the LN Isoform

Selective expression of SN-agrin in the nervous system (Fig. 3) suggested that BL-associated agrin in nonneural tissue is predominantly if not entirely the LN isoform. We tested this idea in two ways. First, we used lacZ histochemistry and in situ hybridization to map SN- and LN-agrin expression in cells that abut BLs. In skin, epidermal cells abutting the BL that separates the dermis from the epidermis were positive for LN-agrin based on lacZ staining (Fig. 6 G). In the developing kidney, glomeruli and a subset of tubules were positive for LN-agrin (Fig. 6 J). In the lung, LN-agrin was expressed primarily by pulmonary epithelial cells (Fig. 6 K). In contrast, SN-agrin RNA was undetectable in all nonneural tissues tested, including lung, kidney, and skin, in which LN is abundant (Fig. 6, M and N; and data not shown).

Second, we used immunohistochemistry to map the distribution of agrin protein in agrin^{LN/LN} mutants. As reported previously and discussed above, agrin is present in numerous BLs of wild-type mice, including microvascular BLs in brain (Fig. 7 A), glomerular BL in kidney (Fig. 7 C), and meningeal sheaths (Fig. 7 E), as well as skin, retina, and lung (not shown). No agrin immunoreactivity was detectable in any of these sites in agrin^{LN/LN} embryos and neonates (Fig. 7, B, D, and F; and data not shown). The lack of staining did not reflect disappearance of the BL, as

shown by staining with antibodies to broadly distributed BL components such as laminin (Fig. 7, G and H; and data not shown). Together, these results show that all detectable BL-associated agrin is of the LN isoform, and that agrin is not essential for formation of BLs.

Impaired Synapse Formation in the Absence of LN-Agrin

Agrin^{LN/LN} mice died at birth and exhibit no spontaneous movements, including respiratory movements. In this respect, the LN-specific mutants resembled mice lacking all forms of agrin or the bioactive Z-agrin isoform, both of which fail to form neuromuscular junctions (Gautam et al., 1996; Burgess et al., 1999; Burgess, R.W., and J.R. Sanes, manuscript in preparation).

Histological analysis demonstrated that neuromuscular structure was drastically disrupted in agrin^{LN/LN} muscles. In wild-type muscles, motor axons form a central nerve trunk; individual axons leave the trunk, branch, and terminate on myotubes (Fig. 8 A). Each nerve terminal organizes a postsynaptic apparatus, rich in AChRs (Fig. 8 A') and acetylcholinesterase (Fig. 8 C). In agrin^{LN/LN} muscles, intramuscular nerve trunks form, but motor axons sprout abnormally and form few nerve terminals (Fig. 8 B). Few AChR clusters and acetylcholinesterase deposits form (Fig. 8, B' and D). Those AChR clusters that do form are smaller and dimmer than those in control muscles (insets in Fig. 8, A' and B'), and fewer than half of them are apposed to nerve terminals. In all these respects, the synaptic defects observed in agrin^{LN/LN} muscle are identical to those previously documented in detail for other agrin mutants (Gautam et al., 1996, 1999; Burgess et al., 1999).

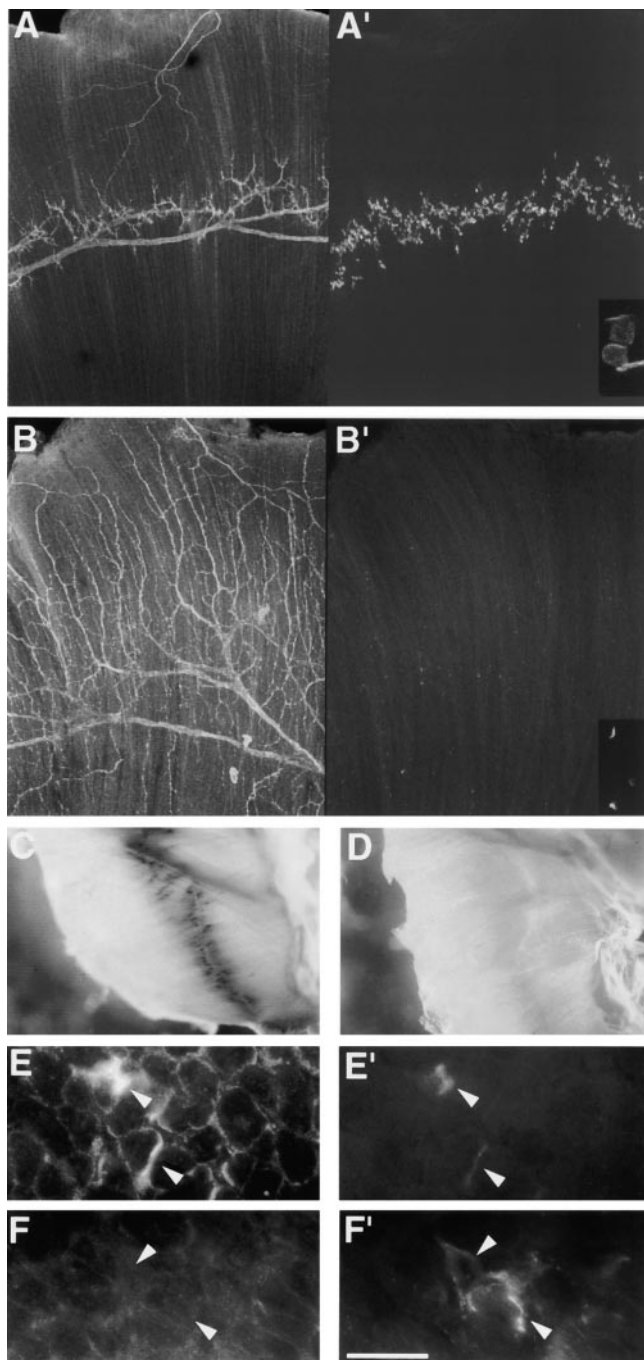

Figure 8. Neuromuscular junctions fail to form in *agrin*^{LN/LN} muscle. (A and B) Diaphragms from E18 mice were stained with antibodies against neurofilaments and synaptophysin to visualize axons (A and B) and with α -bungarotoxin to visualize AChRs (A' and B'). In wild-type mice (A and A'), the synapses form a narrow endplate band in the center of the muscle. Plaques of AChRs are clear and bright (A', inset). In *agrin*^{LN/LN} muscle (B and B'), neurites fail to stop at synaptic sites and little postsynaptic specialization is seen. Small, dim clusters of AChRs are present (B', inset), but they are usually not apposed to nerves. (C and D) Acetylcholinesterase accumulates in the endplate band of E18 control muscles (C) but not *agrin*^{LN/LN} muscles (D). At E18, agrin is present in the extra-synaptic basal lamina of control myotubes, as shown in cross-sections of intercostal muscle (E). All muscle agrin staining is eliminated in *agrin*^{LN/LN} mice (F). Motor nerve terminal, identified by SV2 staining (E' and F') are associated with agrin accumulations in wild-type (E and E') but not mutant (F and F') muscles, suggesting that most synaptic agrin is of the LN form. Bar: (A and B) 50 μ m; (C and D) 100 μ m; (A' and B', insets) 20 μ m; and (E and F) 20 μ m.

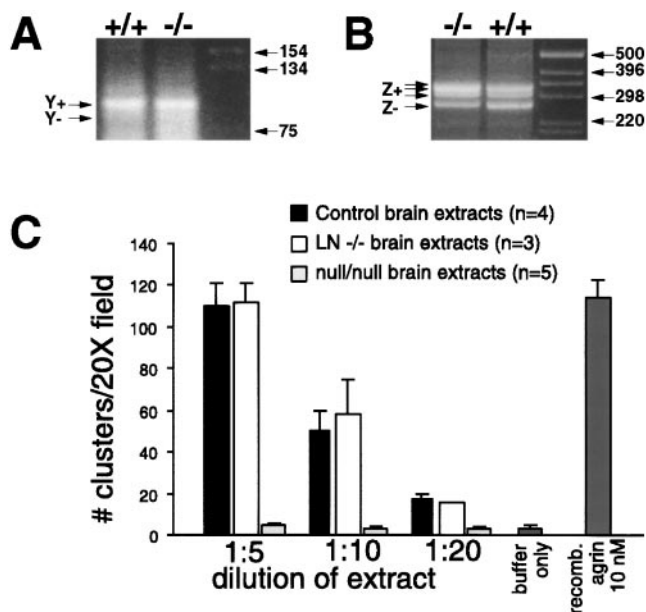

Figure 9. SN-agrin is bioactive. (A and B) RT-PCR of RNA from brains of E18 *agrin*^{LN/LN} mice and littermate controls, using primers that span the Y (A) and Z (B) exons. Both Y⁺ and Y⁻ transcripts are present in both genotypes with Y⁺ transcripts predominant. Multiple Z⁺ transcripts (with 24-, 33-, and 57-bp inserts) as well as Z⁻ transcripts are also present in similar proportions in wild-type and mutant brains, indicating that SN-agrin is subject to alternative splicing at sites that determine its bioactivity. (C) Brain extracts from *agrin*^{LN/LN} mice were applied to cultured primary myotubes and clustering activity was assayed. The activity of control and mutant brain extracts was the same, suggesting that SN-agrin is capable of inducing AChR clusters in vitro. Virtually all clustering activity is due to agrin since extracts from a agrin null mutant induce few clusters (Burgess, R.W., and J.R. Sanes, manuscript in preparation; redrawn as light gray bars).

We also examined the distribution of agrin in muscles of control and *agrin*^{LN/LN} neonates. In wild-type adult muscles, agrin is highly concentrated in the BL of the synaptic cleft (McMahan, 1990). In embryos, however, agrin is present throughout the myotube BL (Hoch et al., 1993); a concentration of agrin immunoreactivity at synaptic sites becomes detectable around the time of birth (Fig. 8, E and E'). In *agrin*^{LN/LN} mutants, no agrin was detectable in myotube BL, consistent with our conclusion that all BL-associated agrin is of the LN form (Fig. 8 F). Importantly, agrin was also undetectable at sites of nerve-myotube contact in mutant muscles (Fig. 8, F and F'), indicating that most if not all synaptic agrin, presumably including motoneuron-derived agrin, is also of the LN form.

SN-Agrin Has AChR Clustering Activity

The similar neuromuscular defects of *agrin*^{LN/LN} and agrin null mutants raised the possibility that SN-agrin is incapable of inducing postsynaptic differentiation. We tested this idea in two ways. First, we assessed the alternative splicing pattern of SN-agrin transcripts. Previous studies have shown that inclusion of either exon 32, 33, or both at a 3' site called "Z" markedly enhances AChR clustering activity in vitro and is necessary for synaptic differentiation in vivo (see Introduction). In addition, inclusion of exon 28 at a nearby site called "Y" is required for agrin to bind to heparin, although the physiological significance of this

binding is unknown (Gesemann et al., 1996; Burgess et al., 1999). We therefore used RT-PCR to determine the Y and Z splice forms of agrin present in agrin^{LN/LN} mice. As LN transcripts are undetectable in these animals (Fig. 5, B and F), all residual agrin in these mutants is likely to be SN-agrin. The remaining transcripts included those that were Y⁺, Y⁻, Z⁺, and Z⁻. Moreover, the proportions of the various forms did not differ appreciably between mutants and littermate controls (Fig. 9, A and B). Thus SN- as well as LN-agrin bears the Z exons required for synaptic organizing activity.

Second, we used myotube cultures to test whether LN-agrin accounts for all of the bioactive agrin in the central nervous system. Cultures were incubated for 18 h with extracts from wild-type brain and spinal cord and then stained with rhodamine- α -bungarotoxin to label AChRs. Extracts from wild-type brain induced a dose-dependent increase in the number of AChR clusters. Extracts from agrin null mutants were nearly inactive in this assay, indicating most of the AChR clustering activity in soluble extracts of the central nervous system is attributable to agrin (Burgess, R.W., and J.R. Sanes, manuscript in preparation; redrawn as light gray bars in Fig. 9 C). Extracts from agrin^{LN/LN} tissue were nearly as effective in inducing AChR clusters as extracts from littermate controls (Fig. 9 C). Together, these results provide evidence that SN-agrin has AChR-clustering activity in vitro. The result that levels of this bioactivity are similar in control and agrin^{LN/LN} brains presumably reflects the fact that LN/Z⁺ agrin has a limited distribution: there is more SN- than LN-agrin in neurons, most of the Z⁺ agrin in brain is likely to be SN/Z⁺, and most of the LN agrin is likely to be LN/Z⁻. We therefore believe that the requirement for LN-agrin in postsynaptic differentiation reflects the appropriate cellular (motoneurons) and subcellular (BL) localizations of this isoform.

Discussion

Molecular cloning of agrin from rat and chick revealed that the protein sequences are highly conserved between species with the exception of their NH₂ termini, which display no similarity at all. We have now shown that this divergence reflects the existence of two agrin isoforms in which distinct NH₂ termini of 49 aa (ratlike or SN) or 150 aa (chicklike or LN) are fused to ~1,900 aa of common sequence. The two isoforms are expressed in different patterns, with LN-agrin being broadly expressed and SN-agrin being selectively expressed in the nervous system. We believe these patterns are regulated transcriptionally by elements near the 5' end of the gene. In addition, SN and LN-agrin are localized to different compartments, with LN being matrix associated and SN being attached to plasma membranes. These differences are determined by unique SN and LN NH₂-terminal sequences. Interestingly, inclusion of alternatively spliced segments in the COOH-terminal quarter of agrin, which affect the bioactivity and binding properties of the protein, are regulated independently of the choice between SN and LN isoforms. We propose that transcriptional regulation, alternative use of NH₂ termini and alternative splicing of COOH termini act

together to generate proteins with appropriate activities at appropriate sites.

Gene Expression

LN-agrin is broadly expressed in neural and nonneural tissues alike, whereas SN-agrin is selectively expressed in the nervous system. Within the nervous system, LN- and SN-agrins are also expressed in different patterns: SN is expressed by many postmitotic neurons whereas LN is expressed by neuroblasts, glia, cells of the microvasculature, and restricted neuronal subpopulations, most notably motoneurons.

The distinct distributions of SN- and LN-agrin RNAs could result from any or all of three mechanisms: (a) tissue-specific alternative splicing; (b) alternative promoter usage; or (c) tissue-specific differences in mRNA stability. We have no data that bear directly on the third possibility, but view it as unlikely and note that it would likely to act in conjunction with one of the other two. In contrast, we have two reasons for believing that expression patterns reflect transcriptional regulation rather than regulated splicing of a common transcript. The essential point is that alternative splicing of a single transcript would require the existence of a common upstream exon encoding untranslated sequences, which would be spliced to either the LN or the SN exons. However, the size of the SN-agrin mRNA seen on Northern blots is accounted for by the size of the SN exon plus known common translated and untranslated sequences (Rupp et al., 1992). Therefore, any common upstream exon would have to be quite small. Second, and more compelling, the gene trap insertion in the agrin^{LN} allele would be expected to intercept all transcripts initiated from the hypothetical upstream exon, whether or not they also included LN exons. In fact, however, the trap intercepts LN transcripts virtually completely, yet has no detectable effect on the level of SN transcripts. This result suggests that the insertion downstream of the LN exons and upstream of the SN exon which is between the LN- and SN-agrin transcriptional start sites. This arrangement, in turn, implies that LN- and SN-agrin RNAs are transcribed from different promoters, each associated with tissue-specific regulatory elements. A testable prediction of our model is that an SN-agrin promoter and neuron-specific enhancer lie in the <4-kb interval between the agrin^{LN} insert and the SN-specific exon.

Protein Localization

Three lines of evidence indicate that LN-agrin is associated with BLs. First, recombinant full-length chick (LN) agrin binds to BL components, including laminin (Denzer et al., 1995, 1997). Second, nonneural tissues, in which agrin is known to be associated with BLs, express LN-agrin but not SN-agrin (Figs. 3 and 6). Third, no agrin is detectable in BLs of agrin^{LN/LN} mice, which express SN-agrin but not LN-agrin (Fig. 7). In contrast, SN-agrin appears to be associated with cell surfaces. Recombinant, full-length rat (SN) agrin remains attached to cell membranes when synthesized and secreted by transfected cells (Campanelli et al., 1991; and Fig. 2). Furthermore, agrin is associated with axonal and synaptic membranes of neurons, which express SN-agrin (Mann and Kroger, 1996;

Halfter et al., 1997; Koulen et al., 1999). Interestingly, motoneurons, which secrete agrin into BLs, are among the few neuronal types that express LN- as well as SN-agrin.

The different subcellular localizations of LN- and SN-agrin are attributable to their unique NH₂-terminal sequences. Denzer et al. (1997) generated a fusion protein consisting of the chick NH₂ terminus including LN-specific residues fused to an immunoglobulin tag. This protein bound to a BL extract (Matrigel) and to purified laminin. Conversely, a chick agrin protein lacking the NH₂-terminal sequences was unable to bind Matrigel or laminin. In a conceptually similar experiment, we generated a fusion protein in which the NH₂ terminus of mouse SN-agrin is fused to a FLAG epitope tag, and showed that this fusion is externalized but remains associated with the surfaces of cells that express it (Fig. 2). Thus, unique SN and LN sequences can endow heterologous proteins with the ability to associate with cell membranes and BLs, respectively. For LN-agrin, a direct binding of the LN sequences to domain I/II of the laminin γ 1 chain has been demonstrated (Kammerer et al., 1999). For SN-agrin, the mode of membrane association remains to be determined. It is noteworthy that the unique SN sequences contain neither a canonical signal peptide nor a predicted transmembrane domain. It will be interesting to learn how SN sequences are externalized and how they associate with the membrane.

Association of Y and Z Exons with LN and SN

Previous studies of agrin isoforms have focussed on its COOH-terminal variants. As noted in the Introduction, inclusion of Z exons endows agrin with the ability to organize postsynaptic differentiation and inclusion of Y exons endows agrin with the ability to bind heparin. Our results (Figs. 3, 6, 8, and 9), taken together with those of previous studies (Ferns et al., 1992, 1993; Hoch et al., 1993; O'Connor et al., 1994; Ma et al., 1995; Cohen et al., 1997b; Burgess et al., 1999), provide several lines of evidence that both LN- and SN-agrin transcripts can either include or exclude the Y and Z exons. (a) Nonneural cells, for example in kidney or muscle, express LN-agrin but not SN-agrin and Z⁻ but not Z⁺ agrin; this agrin is therefore LN/Z⁻. (b) Likewise, the presence of both Y⁺ and Y⁻ agrin in nonneural tissues argues for the existence of LN/Y⁻ and LN/Y⁺ species. (c) Motoneurons express both LN and SN-agrin and both Z⁺ and Z⁻ agrin. However, LN and Z⁺ agrin are required for synaptogenesis at the neuromuscular junction, whereas SN (either Z⁺ or Z⁻) and Z⁻ (either SN or LN) agrin are insufficient. The simplest explanation is that the nerve-derived organizer of postsynaptic differentiation is LN/Z⁺ agrin. (d) RT-PCR analysis of residual agrin in the agrin^{LN/LN} mutant reveals both Z⁺ and Z⁻ populations. On the assumption that the residual agrin is SN-agrin, both SN/Z⁺ and SN/Z⁻ RNAs must exist. (e) Similar RT-PCR analysis provides evidence for SN/Y⁺ and SN/Y⁻ species. (f) The presence of abundant AChR-clustering activity in the brains of agrin^{LN/LN} mutants provides additional evidence for the existence of SN/Z⁺ agrin.

Proper agrin function requires that appropriate agrin isoforms be expressed by specific cells and localized to particular subcellular domains. We propose that combina-

torial usage of putative transcriptional regulatory elements (that drive expression of SN and LN-agrin), NH₂-terminal sequences (that promote association with membranes or BL) and alternatively spliced COOH-terminal sequences (that regulate bioactivity) account for many aspects of the proper matching of localization to function.

The only proven activity of agrin *in vivo* is to organize the neuromuscular junction. As discussed above, this activity is mediated by the LN/Z⁺ form expressed by motor neurons. The LN/Z⁻ splice form is a component of numerous BLs. Our work demonstrates that agrin is not required for the formation of these BLs, but it may have structural or signaling roles postnatally (see Introduction). We are presently unable to investigate such roles *in vivo* due to the neonatal lethality of currently available agrin mutants. Particularly intriguing is the possibility that SN-agrin plays roles in the development or function of central neurons. Several lines of evidence including the expression pattern (Ma et al., 1995; Stone and Nikolic, 1995; Cohen et al., 1997b) and localization (Escher et al., 1996; Mann and Kroger, 1996; Halfter et al., 1997; Koulen et al., 1999) of agrin suggest it is involved in interneuronal synaptogenesis. Furthermore, signal-transducing receptors for agrin appear to be present on cultured neurons (Ji et al., 1998; Hilgenberg et al., 1999; see also Martin and Sanes, 1997). Two studies of cultured neurons have failed to demonstrate roles for agrin in neuron–neuron synaptogenesis (Li et al., 1999; Serpinskaya et al., 1999) but a third study has reported that agrin antisense oligodigonucleotides inhibit synapse formation (Ferreira, 1999). Unfortunately, as for BL, subtle or postnatal roles of agrin in brain have not been testable *in vivo*, owing to neonatal lethality. Because most of the agrin in central neurons is SN-agrin, whereas motoneuronal agrin is largely of the LN isoform, selective elimination of the SN exon may provide a suitable strategy for studying roles of agrin in the brain.

We thank Jeanette Cunningham, James Gross, Renate Lewis, and Mia Wallace for assistance; Yong Yin for Fig. 6 F; and Guoping Feng and Jeff Miner for helpful discussion.

This work was supported by grants from the National Institutes of Health to R.W. Burgess and J.R. Sanes; W.C. Skarnes was a Searle Scholar.

Submitted: 30 June 2000

Revised: 14 August 2000

Accepted: 24 August 2000

References

- Barber, A.J., and E. Lieth. 1997. Agrin accumulates in the brain microvascular basal lamina during development of the blood-brain barrier. *Dev. Dyn.* 208: 62–74.
- Buckley, K., and R.B. Kelly. 1985. Identification of a transmembrane glycoprotein specific for secretory vesicles of neural and endocrine cells. *J. Cell Biol.* 100:1284–1294.
- Burgess, R.W., Q.T. Nguyen, Y.J. Son, J.W. Lichtman, and J.R. Sanes. 1999. Alternatively spliced isoforms of nerve- and muscle-derived agrin: their roles at the neuromuscular junction. *Neuron*. 23:33–44.
- Campanelli, J.T., W. Hoch, F. Rupp, T. Kreiner, and R.H. Scheller. 1991. Agrin mediates cell contact-induced acetylcholine receptor clustering. *Cell*. 67:909–916.
- Campanelli, J.T., G.G. Gayer, and R.H. Scheller. 1996. Alternative RNA splicing that determines agrin activity regulates binding to heparin and α -dystroglycan. *Development*. 122:1663–1672.
- Cohen, I., M. Rimer, T. Lomo, and U.J. McMahan. 1997a. Agrin-induced postsynaptic-like apparatus in skeletal muscle fibers *in vivo*. *Mol. Cell. Neurosci.* 9:237–253.
- Cohen, N.A., W.E. Kaufmann, P.F. Worley, and F. Rupp. 1997b. Expression of

- agrin in the developing and adult rat brain. *Neuroscience*. 76:581–596.
- Denzer, A.J., M. Gesemann, B. Schumacher, and M.A. Ruegg. 1995. An amino-terminal extension is required for the secretion of chick agrin and its binding to extracellular matrix. *J. Cell Biol.* 131:1547–1560.
- Denzer, A.J., R. Brandenberger, M. Gesemann, M. Chiquet, and M.A. Ruegg. 1997. Agrin binds to the nerve-muscle basal lamina via laminin. *J. Cell Biol.* 137:671–683.
- Escher, G., C. Bechade, S. Levi, and A. Triller. 1996. Axonal targeting of agrin in cultured rat dorsal horn neurons. *J. Cell. Sci.* 109:2959–2966.
- Ferns, M., W. Hoch, J.T. Campanelli, F. Rupp, Z.W. Hall, and R.H. Scheller. 1992. RNA splicing regulates agrin-mediated acetylcholine receptor clustering activity in cultured myotubes. *Neuron*. 8:1079–1086.
- Ferns, M., J.T. Campanelli, W. Hoch, R.H. Scheller, and Z.M. Hall. 1993. The ability of agrin to cluster AChRs depends on alternative splicing and on cell surface proteoglycans. *Neuron*. 11:491–502.
- Ferreira, A. 1999. Abnormal synapse formation in agrin-depleted hippocampal neurons. *J. Cell Sci.* 112:4729–4738.
- Gautam, M., P.G. Noakes, L. Moscoso, F. Rupp, R.H. Scheller, J.P. Merlie, and J.R. Sanes. 1996. Defective neuromuscular synaptogenesis in agrin-deficient mutant mice. *Cell*. 85:525–535.
- Gautam, M., T.M. DeChiara, D.J. Glass, G.D. Yancopoulos, and J.R. Sanes. 1999. Distinct phenotypes of mutant mice lacking agrin, MuSK, or rapsyn. *Brain Res. Dev. Brain Res.* 114:171–178.
- Gesemann, M., A.J. Denzer, and M.A. Ruegg. 1995. Acetylcholine receptor-aggregating activity of agrin isoforms and mapping of the active site. *J. Cell Biol.* 128:625–636.
- Gesemann, M., V. Cavalli, A.J. Denzer, A. Brancaccio, B. Schumacher, and M.A. Ruegg. 1996. Alternative splicing of agrin alters its binding to heparin, dystroglycan, and the putative agrin receptor. *Neuron*. 16:755–767.
- Groffen, A.J., C.A. Buskens, T.H. van Kuppevelt, J.H. Veerkamp, L.A. Monnens, and L.P. van den Heuvel. 1998a. Primary structure and high expression of human agrin in basement membranes of adult lung and kidney. *Eur. J. Biochem.* 254:123–128.
- Groffen, A.J., M.A. Ruegg, H. Dijkman, T.J. van de Velden, C.A. Buskens, J. van den Born, K.J. Assmann, L.A. Monnens, J.H. Veerkamp, and L.P. van den Heuvel. 1998b. Agrin is a major heparan sulfate proteoglycan in the human glomerular basement membrane. *J. Histochem. Cytochem.* 46:19–27.
- Halfter, W., B. Schurer, J. Yip, L. Yip, G. Tsen, J.A. Lee, and G.J. Cole. 1997. Distribution and substrate properties of agrin, a heparan sulfate proteoglycan of developing axonal pathways. *J. Comp. Neurol.* 383:1–17.
- Hilgenberg, L.G., C.L. Hoover, and M.A. Smith. 1999. Evidence of an agrin receptor in cortical neurons. *J. Neurosci.* 19:7384–7393.
- Hoch, W., M. Ferns, J.T. Campanelli, Z.W. Hall, and R.H. Scheller. 1993. Developmental regulation of highly active alternatively spliced forms of agrin. *Neuron*. 11:479–490.
- Ji, R.R., C.M. Bose, C. Lesuisse, D. Qiu, J.C. Huang, Q. Zhang, and F. Rupp. 1998. Specific agrin isoforms induce cAMP response element binding protein phosphorylation in hippocampal neurons. *J. Neurosci.* 18:695–702.
- Kammerer, R.A., T. Schulthess, R. Landwehr, B. Schumacher, A. Lustig, P.D. Yurchenco, M.A. Ruegg, J. Engel, and A.J. Denzer. 1999. Interaction of agrin with laminin requires a coiled-coil conformation of the agrin-binding site within the laminin gamma1 chain. *EMBO J.* 18:6762–6770.
- Kanwar, Y.S., Z.Z. Liu, N. Kashihara, and E.I. Wallner. 1991. Current status of the structural and functional basis of glomerular filtration and proteinuria. *Semin. Nephrol.* 11:390–413.
- Koulen, P., L.S. Honig, E.L. Fletcher, and S. Kroger. 1999. Expression, distribution and ultrastructural localization of the synapse-organizing molecule agrin in the mature avian retina. *Eur. J. Neurosci.* 11:4188–4196.
- Li, Z., L.G. Hilgenberg, D.K. O'Dowd, and M.A. Smith. 1999. Formation of functional synaptic connections between cultured cortical neurons from agrin-deficient mice. *J. Neurobiol.* 39:547–557.
- Ma, E., R. Morgan, and E.W. Godfrey. 1995. Agrin mRNA variants are differentially regulated in developing chick embryo spinal cord and sensory ganglia. *J. Neurobiol.* 26:585–597.
- Mann, S., and S. Kroger. 1996. Formation of synaptic specializations in the inner plexiform. *Mol. Cell. Neurosci.* 8:1–13.
- Martin, P.T., and J.R. Sanes. 1997. Integrins mediate adhesion to agrin and modulate agrin signaling. *Development*. 124:3909–3917.
- McMahan, U.J. 1990. The agrin hypothesis. *Cold Spring Harb. Symp. Quant. Biol.* 55:407–418.
- Meier, T., D.M. Hauser, M. Chiquet, L. Landmann, M.A. Ruegg, and H.R. Brenner. 1997. Neural agrin induces ectopic postsynaptic specializations in innervated muscle fibers. *J. Neurosci.* 17:6534–6544.
- O'Connor, L.T., J.C. Lauterborn, C.M. Gall, and M.A. Smith. 1994. Localization and alternative splicing of agrin mRNA in adult rat brain: transcripts encoding isoforms that aggregate acetylcholine receptors are not restricted to cholinergic regions. *J. Neurosci.* 14:1141–1152.
- O'Toole, J.J., K.A. Deyst, M.A. Bowe, M.A. Nastuk, B.A. McKechnie, and J.R. Fallon. 1996. Alternative splicing of agrin regulates its binding to heparin, a-dystroglycan, and the cell surface. *Proc. Natl. Acad. Sci. USA*. 93:7369–7374.
- Raats, C.J., J. Van Den Born, and J.H. Berden. 2000. Glomerular heparan sulfate alterations: mechanisms and relevance for proteinuria. *Kidney Int.* 57:385–400.
- Ruegg, M.A., K.W.K. Tsim, S.E. Horton, S. Kroger, G. Escher, E.M. Gensch, and U.J. McMahan. 1992. The agrin gene codes for a family of basal lamina proteins that differ in function and distribution. *Neuron*. 8:691–699.
- Rupp, F., D.G. Payan, C. Magill-Solc, D.M. Cowan, and R.H. Scheller. 1991. Structure and expression of a rat agrin. *Neuron*. 6:811–823.
- Rupp, F., T. Ozcelik, M. Linial, K. Peterson, U. Francke, and R. Scheller. 1992. Structure and chromosomal localization of the mammalian agrin gene. *J. Neurosci.* 12:3535–3544.
- Sanes, J.R., D.H. Feldman, J.M. Cheney, and J.C. Lawrence. 1984. Brain extract induces synaptic characteristics in the basal lamina of cultured myotubes. *J. Neurosci.* 4:464–473.
- Sanes, J.R., J.L.R. Rubenstein, and J.-F. Nicolas. 1986. Use of a recombinant retrovirus to study post-implantation cell lineage in mouse embryos. *EMBO J.* 5:3133–3142.
- Schaeren-Wiemers, N., and A. Gerfin-Moser. 1993. A single protocol to detect transcripts of various types and expression levels in neural tissue and cultured cells: in situ hybridization using digoxigenin-labelled cRNA probes. *Histochemistry*. 100:431–440.
- Serpinskaya, A.S., G. Feng, J.R. Sanes, and A.M. Craig. 1999. Synapse formation between agrin mutant hippocampal neurons. *Dev. Biol.* 205:65–78.
- Skarnes, W.C., J.E. Moss, S.M. Hurtley, and R.S.P. Beddington. 1995. Capturing genes encoding membrane and secreted proteins important for mouse development. *Proc. Natl. Acad. Sci. USA*. 92:6592–6596.
- Smith, M.A., C. Magill-Solc, F. Rupp, Y.M. Yao, J.W. Schilling, P. Snow, and U.J. McMahan. 1992. Isolation and characterization of a cDNA that encodes an agrin homolog in the marine ray. *Mol. Cell Neurosci.* 3:406–417.
- Stone, D.M., and K. Nikolics. 1995. Tissue- and age-specific expression patterns of alternatively spliced agrin mRNA transcripts in embryonic rat suggest novel developmental roles. *J. Neurosci.* 15:6767–6778.
- Townley, D.J., B.J. Avery, B. Rosen, and W.C. Skarnes. 1997. Rapid sequence analysis of gene trap integrations to generate a resource of insertional mutations in mice. *Genome Res.* 7:293–298.
- Tsen, G., A. Napier, W. Halfter, and G.J. Cole. 1995. Identification of a novel alternatively spliced agrin mRNA that is preferentially expressed in non-neuronal cells. *J. Biol. Chem.* 270:15934–15937.
- Tsim, K.W., M.A. Ruegg, G. Escher, S. Kroger, and U.J. McMahan. 1992. cDNA that encodes active agrin. *Neuron*. 8:677–689 (erratum published *Neuron*. 9:381).
- von Heijne, G. 1986. A new method for predicting signal sequence cleavage sites. *Nucleic Acids Res.* 14:4683–4690.